



Model 951

Orifice Plates

Concentric-Segmental-Eccentric

The most common primary flow element is the concentric orifice plate, often called the “sharp-edged” orifice plate. Its main advantages are: low cost, accuracy, ease of installation, variety of construction material and quick delivery. Much test data has been compiled about orifice plates and, with the necessary information, an exacting design can be made providing for excellent metering accuracy.

Engineered for each application, Meriam orifice plates are precision bored to exact dimensions with a sharp upstream edge to ensure accuracy. Orifice information is stamped on the unique handle. This handle is designed to facilitate storage of the plate without damage to the orifice bore.

Standard Meriam orifice plates are 304 Stainless Steel. Monel, brass, P.V.C., 316 Stainless Steel and other materials are available. Meriam orifice plate dimensions meet ISA specifications. Meriam can provide blank orifice plates for your own boring, too.

Orifice Plates Design Criteria & Tolerances

Standards and specifications for orifice plates are listed by the ISA, AGA and ASME.

All of these do not agree in all ways. Please indicate which specifications you require so we will provide your orifice plates the way you want them.

Edges – Square and sharp, will not reflect a beam of light when viewed without magnification.

Finish – 15-32 micro-inch roughness

Flatness – Flatness within 0.010 inches, per inch of dam height.

Bore – Orifice bore tolerance in strict accordance with AGA. Gas Measurement Committee Report No. 3, ASME Fluid Meters Committee Report, and with other societies’ recommendations.

Meriam has furnished many orifice plates for nuclear and fossil fired power plants, chemical plants, refineries, steel mills and to original equipment manufacturers for incorporation in their equipment and systems.

Meriam can also provide readout instruments and accessories for complete flow metering installation.

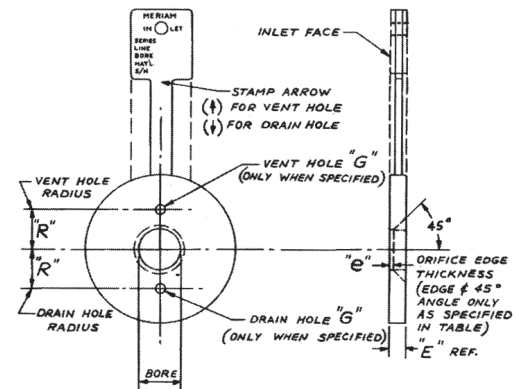

Orifice Edge Thickness

Line Pipe Size	1/2"-1 1/2"	2" - 3"	3 1/2"-6"	8"-12"	14"-36"
Orifice Edge Thickness "e"	1/64"	1/32"	1/16"	1/8"	1/4"

Tolerances for Orifice Bore

Orifice Bore	Plus or Minus Tolerances
Less Than .250"	.0003
.250" to .499"	.0004
.500" to 1.999"	.0005
2.000" to 3.999"	.0010
4.000" to 9.999"	.0020
10.000" to 19.999"	.0050
20.000" & up	.0100

Vent/Drain Hole Diameter

Orifice Bore	Vent or Drain Holes "G"
Less than 1.000"	None
1.000 to 3.500"	3/32"
3.501 to 4.125"	1/8"
4.126 to 5.000"	5/32"
5.001 to 6.000"	3/16"
6.001 to 6.750"	7/32"
6.751 to 7.500"	1/4"
7.501 to 8.375"	9/32"
8.376 to 9.250"	5/16"
9.251 to 10.000"	11/32"
10.001 to 10.875"	3/8"
10.876 to 11.625"	13/32"
11.626 to 12.500"	7/16"
12.501 to 13.250"	15/32"
13.251" & larger	1/2"

Model 951

Orifice Plates Concentric-Segmental-Eccentric

Orifice Bore Calculations

The Meriam Engineering Department will calculate orifice bore sizes utilizing an inhouse computer.

Bore calculations are based on the LK. Spink precision bore calculations.

Tabulate your flow data and send it to Meriam with your order for precise bore sizing.

Ordering Information

To order Meriam's Model 951 orifice plates custom-made to your specifications, please contact your Meriam sales representative with the following information:

- Flange Rating
- Line Size
- Bore Dimensions, if available (if unknown, consult factory)

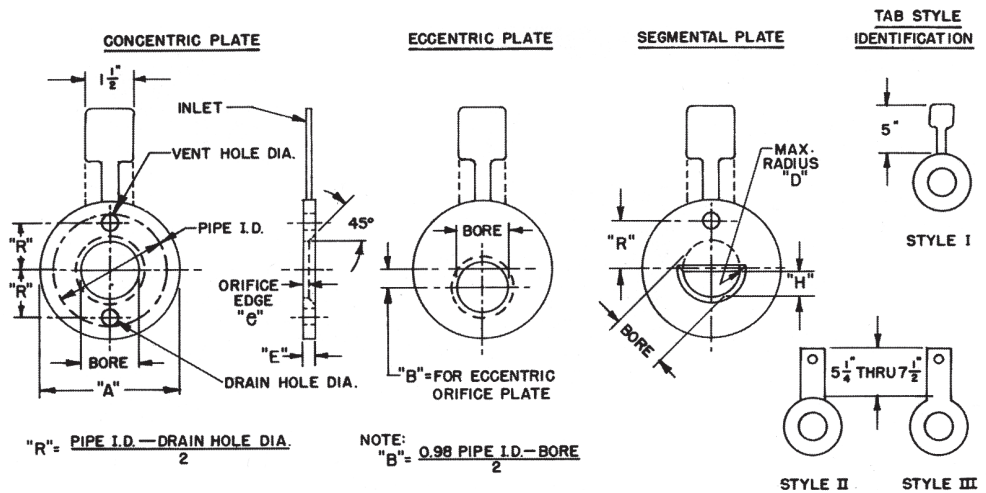

Dimensions Table

Line Pipe Size	1/2"	3/4"	1"	1 1/4"	1 1/2"	2"	2 1/2"	3"	4"	5"	6"	8"	10"	12"	14"	16"	18"	20"	22"	24"	
Meriam Model	"A" Orifice Plate O.D.																				
951C15	125-150# Series	1 7/8"	2 1/4"	2 5/8"	3"	3 3/8"	4 1/8"	4 7/8"	5 3/8"	6 7/8"	7 3/4"	8 3/4"	11"	13 3/8"	16 1/8"	17 3/4"	20 1/4"	21 5/8"	23 7/8"	26"	28 1/4"
951B30	250# Series 300# Series	— 2 1/8"	2 7/8"	2 5/8"	3 1/4"	3 3/4"	4 3/8"	5 1/8"	5 7/8"	7 1/8"	8 1/2"	9 7/8"	12 1/8"	14 1/4"	16 5/8"	19 1/8"	21 1/4"	23 1/2"	25 3/4"	27 3/4"	30 1/2"
951B40	400# Series	2 1/8"	2 5/8"	2 7/8"	3 1/4"	3 3/4"	4 3/8"	5 1/8"	5 7/8"	7"	8 3/8"	9 3/4"	12"	14 1/8"	16 1/2"	19"	21 1/8"	23 3/8"	25 1/2"	27 5/8"	30 1/4"
951B60	600# Series	2 1/8"	2 5/8"	2 7/8"	3 1/4"	3 3/4"	4 3/8"	5 1/8"	5 7/8"	7 5/8"	9 1/2"	10 1/2"	12 5/8"	15 3/4"	18"	19 3/8"	22 1/4"	24 1/8"	26 7/8"	28 7/8"	31 1/8"
951B90	900# Series	2 1/2"	2 3/4"	3 1/8"	3 1/2"	3 7/8"	5 5/8"	6 1/2"	6 5/8"	8 1/8"	9 3/4"	11 3/8"	14 1/8"	17 1/8"	19 5/8"	20 1/2"	22 5/8"	25 1/8"	27 1/2"	—	33"
951B150	1500# Series	2 1/2"	2 3/4"	3 1/8"	3 1/2"	3 7/8"	5 5/8"	6 1/2"	6 7/8"	8 1/4"	10"	11 1/8"	13 7/8"	17 1/8"	20 1/2"	22 3/4"	25 1/4"	27 3/4"	29 3/4"	—	35 1/2"
	Plate Thickness 'E' Meriam STD	1/8"	1/8"	1/8"	1/8"	1/8"	1/8"	1/8"	1/8"	1/8"	1/8"	1/8"	1/8"	1/8"	1/8"	1/4"	1/4"	1/4"	1/4"	1/4"	1/4"
	'E' AGA STD	—	—	—	—	1/8"	1/8"	1/8"	1/8"	1/8"	1/8"	1/8"	1/4"	1/4"	1/4"	3/8"	3/8"	3/8"	3/8"	3/8"	3/8"
	'E' ISA STD	—	—	1/8"	1/8"	1/8"	1/8"	1/8"	1/8"	1/8"	1/8"	1/8"	1/8"	1/8"	1/8"	1/4"	1/4"	1/4"	1/4"	1/4"	1/4"
	ASME	1/8"	1/8"	1/8"	1/8"	1/8"	1/8"	1/8"	1/8"	1/8"	1/8"	1/4"	1/4"	1/4"	1/4"	1/4"	1/4"	1/4"	1/4"	1/4"	1/4"