



User's Manual

Laminar Flow Elements

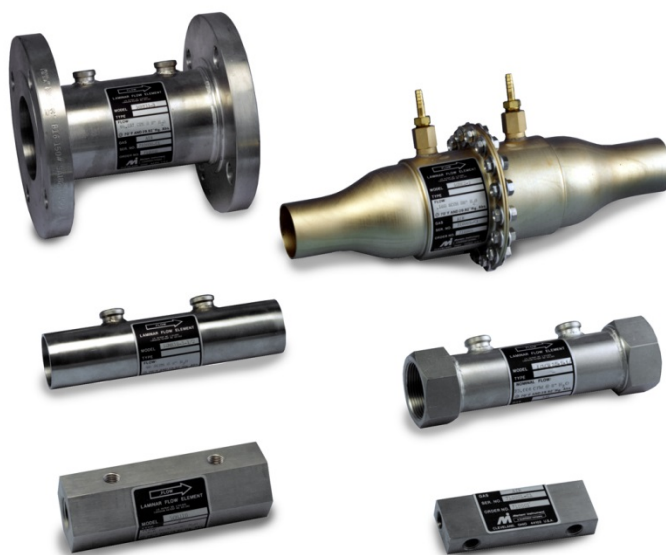

TABLE OF CONTENTS

Subject	Page
Introduction	3
Inspection	3
Installation.....	3
Operation.....	4
Typical Installations	4
Calibration Curve/Table	5
Actual Standard and Mass Flow Equations	5-7
Reading your Laminar Flow Element Curve/Table.....	9
Correction Factor Tables/Curves	
Air Humidity for Density	8
Air Humidity for Viscosity.....	8
Pressure	12
Air Viscosity.....	13
Air Temperature/Viscosity	14
Temperature.....	15
Maintenance	14
Troubleshooting.....	15
LFE Dimensions	17

Introduction

Because of their inherently high accuracy, stable calibration, excellent response time and repeatability, Laminar Flow Elements (LFEs) excel in critical gas and air flow measurements and are frequently utilized in validating calibration standards. Standard models are available to measure as little as 0.2 SCCM (5.9 E-06 SCFM) to as much as 2250 SCFM at standard conditions. Custom models for up to 15,000 SCFM of air are available. Stainless steel or aluminum materials make LFEs compatible with most gases and flow rate of gas mixtures can also be measured when the percentages of component gases and mixture properties are known. Higher accuracies can be achieved when used in conjunction with the Meriam MDT500 multivariable transmitter and software package. The LFE matrix is made from individual SS tubes or windings of SS foil, these tubes are long enough, relative to their inside diameter to cause laminar flow to occur inside each tube, the result is a near linear relationship between DP and flow rate. The DP generated across the matrix responds very quickly to changes in flow and pressure loss to the system is reduced as each LFE is sized to produce no greater than 8" water column at maximum flowing conditions. Individual tube diameters are very small so flowing gases need to be clean and dry to preserve the calibration. Filtered inlet versions of most LFE models are available to keep the matrix clean and the calibration constant.

This manual covers models 50MK10, 50MW20, 50MR2, 50MJ10, 50MC2 and 50MY15. For descriptions, dimensions and capacities of these elements refer to Meriam Bulletin, File No. 501:215

Special Precautions When Handling Matrix Elements

The Meriam LFE depends on the precise fabrication of a matrix metering element for its basic accuracy. These elements are manufactured from .001 inch stainless steel stock and are carefully fabricated. Exercise extreme care when handling the exposed element to make sure the end faces are not gouged or damaged in any fashion. Gouges or damage to the end surfaces may produce nonlinear resistance to flow and introduce error. If the end surface becomes damaged, the accuracy of the element may be restored by recalibration at the factory.

Inspection

1. Make sure you have unpacked all instructions and other data that accompanied the unit.
2. Visually inspect for any signs of damage. There must be no nicks or scratches, surfaces of the LFE should be clear.
3. Units are shipped with a cap plug in each opening which protects the ends and pressure taps. Remove these cap plugs.
4. Visually inspect matrix surface and inside housing. No capillaries should be blocked unless specified in special applications.

Installation

Make sure the line is free of dirt and other foreign materials. The metered gas must be clean. In-line use of filters is recommended. Connections to the differential pressure instrument should be made with equal lengths of 1/4" I.D hose, tubing or pipe. All instrument connections must be leak-free. Install temperature sensor 2-diameters upstream of the element. Inlet absolute pressure instrument, when needed, must be connected close to the LFE at the inlet pressure tap. Figure 1 shows several typical LFE installations.

Install the LFE in the line using hose connectors, flanges, tubing or pipe, as desired. Position the LFE in any orientation. Horizontal is the most common. Orient the high-pressure and low-pressure sensing ports in any angular direction. Flow must be in the direction of the arrow on the LFE. Avoid disturbances upstream of the LFE. Good measurement practices dictate an adequate straight run of the pipe up and downstream of the element. In most installations, 10 diameters upstream and 5 diameters downstream are adequate.

Where installation makes straight pipe runs impossible, LFE's can be calibrated with piping configurations that duplicate installation. This special calibration assures installed accuracy. In these applications, consult Meriam regarding calibration.

Operation

Establish flow through the LFE. Measure the differential pressure between high pressure sensing port and low pressure sensing port. Measure the inlet gas temperature. For standard or mass flow rates, measure absolute line pressure. Refer to calibration curve/table instructions for flow rate calculations.

Standard or Mass Flow Rate

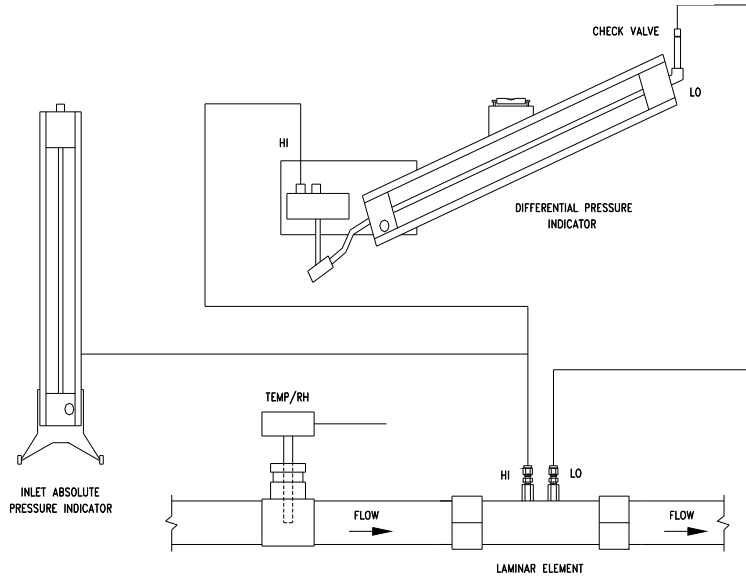

Actual Volumetric Flow Rate

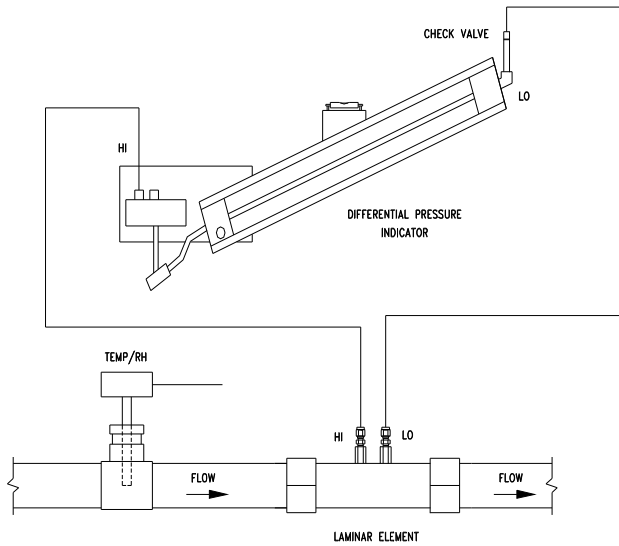

Laminar Flow Systems

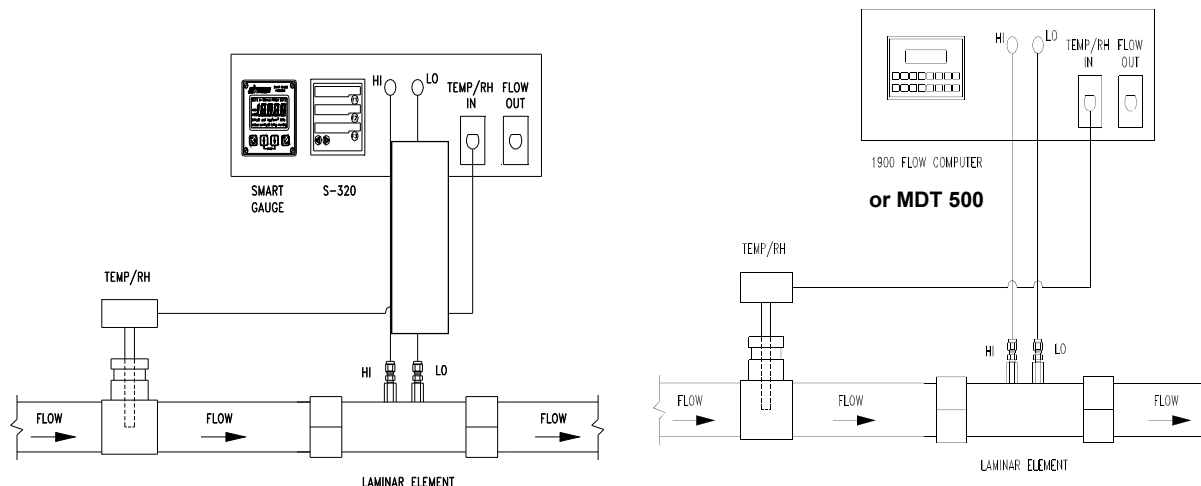

Figure 1: Typical Installations of Laminar Flow Elements Actual, Standard, or Mass Flow

Calibration Curve Table

Meriam performs an air calibration of the LFE using a master flowmeter that is traceable to the National Standards and Technology (NIST). The calibration data is standardized to an equivalent dry gas flow rate at 70°F (21.1°C) and 29.92 inches Hg absolute (101.3 kPa abs.). (The customer may request another standard condition such as 0°C.) It is then possible to determine the actual or standard volumetric flow rate at your flowing conditions. Each LFE has at least one calibration curve or table. The standard curve/table is for dry air flow rate in units of cubic feet per minute (CFM) versus the differential pressure (DP) in inches of water referenced to 4°C produced by the LFE. You may request a curve/table for a different gas and/or for different flow rate units. Each curve/ table is generated using a quadratic (second order) equation.

$$B \times DP + C \times DP^2 = \text{Flow}$$

The calibration constants B and C are printed on each curve/table.

Actual Volumetric Flow Rate

The LFE determines the actual volumetric flow rate. To obtain the actual volumetric flow rate, the differential pressure across the LFE and the inlet temperature to the LFE is measured. Using the calibration curve/table associated with the particular LFE; a flow rate value is obtained by either

- 1) reading the value from the curve/table or:
- 2) using the formula, $B \times DP + C \times DP^2 = \text{Flow}$

Each curve has unique constants B and C. Multiply this flow rate value by the ratio:

$$\frac{(\text{viscosity of flowing gas at } 70^\circ\text{F in micropoise})}{(\text{viscosity of flowing gas at flowing temperature in micropoise})}$$

or $\mu_{\text{std}} / \mu_{\text{f}}$. The product is the actual volumetric flow rate. (The curve/table lists the type of gas used to generate the curve/table.)

$$\text{Actual volumetric flow rate} = (B \times DP + C \times DP^2) \times \left(\frac{\mu_{\text{std}}}{\mu_{\text{f}}} \right)$$

To help calculate the viscosity of air at flowing temperature, a viscosity equation based on temperature is included in this instruction manual (see Table A-32422). The equation is from "tables of Thermodynamic and transport Properties of Air, Argon, Carbon Dioxide, Oxygen, and Steam." All other gas viscosity equations are obtained from "Physical and Thermodynamic Properties of Pure Chemicals" Table A-31986 lists the values of μ_{std} / μ_f for air from 50-159°F at 1° intervals when the standard temperature is 70°F.

*Note: If you are flowing wet air, a humidity correction factor for viscosity must be used. The difference between wet-air viscosity (μ_{wet}) and dry-air viscosity (μ_{dry}) increases with temperature and humidity, at 80°F and 80% relative humidity, the ratio of μ_{wet} / μ_{dry} is .997.

Figure 2 is a graph of the ratio μ_{wet} / μ_{dry} of air from 50 to 150°F and from 10 to 90% relative humidity. The viscosity of the flowing wet air becomes the value from the dry-air viscosity equation times the ratio μ_{wet} / μ_{dry}

$$\mu_f = \mu_{wet\ air} = \left(\frac{14.58 + (T)^{\frac{3}{2}}}{(110.4 + T)} \right) \times \left(\frac{\mu_{wet}}{\mu_{dry}} \right)$$

Where T = °K

The curve/table may have DP units of

- 1) inches of water column (WC)
- 2) centimeters of WC
- 3) millimeters of WC
- 4) pascals
- 5) kilopascals

Whenever a pressure is expressed in units of water, the water temperature reference must be given. The calibration curve uses 4°C for the water temperature reference. Some devices use a water temperature reference of 20°C and others may use other temperature references. If no temperature reference is given on the DP instrument or in its instruction manual, consult the manufacturer. If the DP measuring device has a water temperature reference other than 4°, correct the DP reading by using the following equation:

$$DP @ 4^{\circ}C = DP (\text{device}) \times \frac{\text{density of H}_2\text{O@temperature temperature ref.}}{\text{density of H}_2\text{O@ } 4^{\circ}C}$$

<u>Water Temperature</u>	<u>Water Density (lbs/ft³)</u>
4.0°C (39.2°F)	62.426
20.0°C (68.0°F)	62.316
15.5°C (60.0°F)	62.366
21.1°C (70.0°F)	62.301

The DP @ 4°C value should be used with the curve/table.

Standard Volumetric Flow Rate

The word "standard" when associated with flow rate, means the flow rate has been normalized to an assigned standard pressure and temperature. If standard volumetric flow rate is desired, the actual volumetric flow rate is multiplied by the ratios.

$$\frac{\text{Standard temperature (Tstd)}}{\text{flowing temperature (Tf)}} \text{ and } \frac{\text{flowing pressure (Pf)}}{\text{standard pressure (Pstd)}}$$

Be sure to use the same absolute units for pressure (i.e. PSIA, mm Hg absolute,...) and temperature (°K or °R). The result is the standard volumetric flow rate at the given standard conditions.

$$\text{Standard volumetric flow rate} = \text{Actual volumetric flow rate} \times \left(\frac{T_{\text{std}}}{T_f}\right) \times \left(\frac{P_f}{P_{\text{std}}}\right)$$

$$\text{This equation can be rewritten: } (B \times DP + C \times DP^2) \times \left(\frac{\mu_{\text{std}}}{\mu_f}\right) \times \left(\frac{T_{\text{std}}}{T_f}\right) \times \left(\frac{P_f}{P_{\text{std}}}\right)$$

Table A-31031 lists the values of P_f/P_{std} absolute line pressures from 26”Hg at 0.05” Hg intervals. The standard pressure is 29.92” Hg absolute for this table. Table A-32422 lists the values of $(T_{\text{std}} / T_f) \times (\mu_{\text{std}} / \mu_f)$ for air from 50 to 159°F in 1° intervals. The standard temperature is 70°F (529.67°R) for this table.

Note: If you are flowing wet air, a humidity correction factor for standard volumetric flow rate must be used. The difference between wet-air density (P_{wet}) and dry-air density (P_{dry}) increases with temperature and humidity. At 80°F and 80% relative humidity, the ratio of $P_{\text{wet}} / P_{\text{dry}}$ is .990. Table A-35600 lists the ratio $P_{\text{wet}} / P_{\text{dry}}$ of air from 40 to 100°F and from 20 to 100% relative humidity. The equation for standard volumetric flow rate of flowing wet air becomes:

Standard Volumetric Flow Rate Wet Air =

$$(B \times DP + C \times DP^2) \times \left(\frac{\mu_{\text{std}}}{\mu_{\text{wet air}}}\right) \times \left(\frac{T_{\text{std}}}{T_f}\right) \times \left(\frac{P_f}{P_{\text{std}}}\right) \times \left(\frac{P_{\text{wet}}}{P_{\text{dry}}}\right)$$

Mass Flow Rate

Multiply the standard volumetric flow rate by the density of the flowing gas at standard conditions to obtain the mass flow rate of that gas.

Mass Flow rate = Standard volumetric flow rate x density @ standard conditions

Summary

Curve/table value @ DP = $(B \times DP + C \times DP^2)$

Actual volumetric flow rate = $(B \times DP + C \times DP^2) \times \left(\frac{\mu_{\text{std}}}{\mu_f}\right)$

Standard volumetric flow rate = Actual volumetric flow rate $\times \left(\frac{P_f}{P_{\text{std}}}\right) \times \left(\frac{T_{\text{std}}}{T_f}\right)$

Mass flow rate = Standard volumetric flow rate x density @ standard conditions

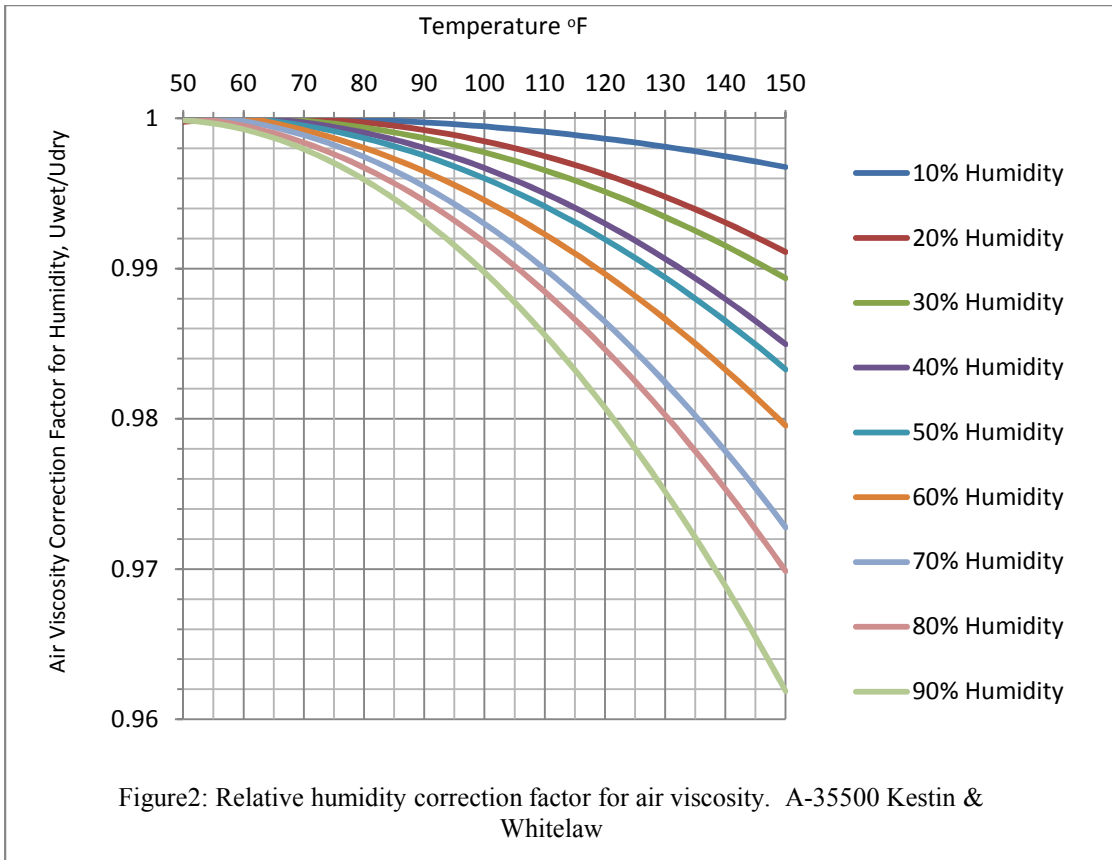

Table A-35600 (NBSIR 83-2652)
Humidity Correction Factor for Air = P_{wet}/P_{dry}

°F	% Relative Humidity				
	20%	40%	60%	80%	100%
40	.9993	.9987	.9981	.9975	.9969
50	.9990	.9981	.9973	.9964	.9955
60	.9986	.9973	.9960	.9948	.9934
70	.9981	.9962	.9944	.9925	.9907
80	.9974	.9948	.9922	.9895	.9870
90	.9964	.9928	.9892	.9855	.9818
100	.9951	.9902	.9854	.9805	.9756

Determining Flow from your Laminar Flow Element Calibration Curve/Table

The curve/table of each LFE is normalized to standard conditions listed by multiplying the calibration data points by the ratio of:

$$\frac{\text{viscosity of gas at calibration temperature}}{\text{viscosity of gas at 70°F (standard temperature)}}$$

Therefore, you should NOT read the flow rate directly from the curve/table unless your flow temperature and pressure are identical to the standard conditions. The following steps must be taken to determine flow rate at flowing conditions other than standard.

1. Measure and correct to 4°C and if necessary, the DP across the LFE.
2. Measure and record the inlet temperature (always) and absolute line pressure (for standard or mass flow rates). Convert both values to absolute units.
3. Follow the AIR FLOW or GAS OTHER THAN AIR guidelines below

Model 50MK10

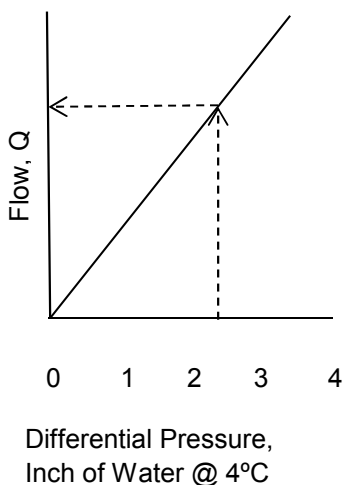

All Other Models

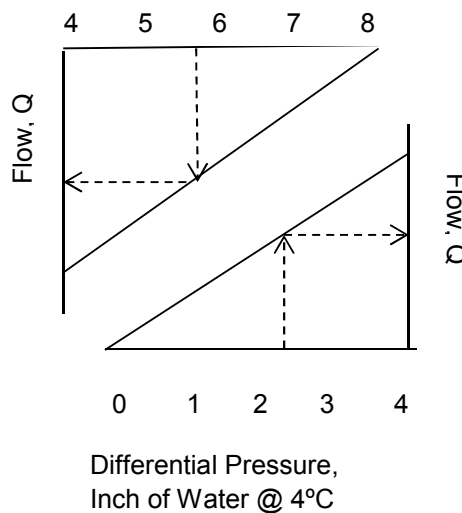

Air Flow

Select the proper flow curve/table for the LFE being used.

Standard Volumetric Flow Rate

- 1) To obtain standard volumetric flow rate if inlet pressure and temperature are other than 29.92" Hg absolute and 70°F, respectively, find the flow rate (Q) that corresponds to the corrected DP. Multiply Q by temperature/viscosity and pressure corrections shown on charts A-32422 and A-31031, respectively, to bring flow to standard conditions of 29.92" Hg and 70°F.
- 2) At flowing conditions of 70°F and 29.92" Hg, read curve directly in standard volumetric flow rate.

Actual Volumetric Flow Rate

- 1) To obtain actual volumetric flow rate at inlet flowing temperature other than 70°F, find the flow rate (Q) that corresponds to the corrected DP. Multiply Q by the viscosity correction only. See chart A-31986 for corrections.
- 2) At flowing inlet temperature of 70°F read curve directly in actual volumetric flow rate.

Actual volumetric flow rate equals standard volumetric flow rate when flowing conditions are 70°F and 29.92" Hg.

Notify Meriam if your flowing gas is not air and/or standard conditions are different from 70°F and 29.92" Hg absolute. A special curve/table can be provided listing the gas being flowed. The gas viscosity correction, μ_{std} / μ_f will reference the gas and/or new standard temperature value, if applicable. Table A-32422 or A-31986 cannot be used for gases other than air.

Gas Flow Other Than Air/Standard Conditions From 70°F and 29.92" Hg ABS.

Select the proper flow curve/table for the LFE being used.

Standard Volumetric Flow Rate

- 1) To obtain standard volumetric flow rate if the inlet temperature and pressure are different from standard, read the flow rate (Q) from the curve/table corresponding to the corrected differential pressure (DP). Calculate the viscosity at the flowing temperature using the viscosity equation for the flowing gas. Then calculate the viscosity correction factor (μ_{cf}) using

$$\mu_{cf} = \frac{\text{Viscosity constant from curve/table}}{\text{flowing gas viscosity at flowing temperature}}$$

Locate the pressure correction factor (Pcf) for the flowing inlet pressure on chart A-31031 or calculate the correction factor using

$$P_{cf} = \frac{\text{absolute inlet line pressure}}{\text{absolute standard pressure}}$$

Locate the temperature correction factor (Tcf) for the flowing temperature on chart A-35700 or calculate using

$$T_{cf} = \frac{\text{absolute standard temperature}}{\text{absolute flowing temperature}}$$

Multiply Q from the curve/table by the viscosity correction factor (μ_{cf}), the pressure correction factor (Pcf) and the temperature correction factor (Tcf). This product will give the flow rate of a particular gas at the standard conditions.

- 2) At flowing inlet conditions equal to the standard conditions, read curve/table directly in standard volumetric flow rate.

Actual Volumetric Flow Rate

1) To obtain actual volumetric flow rate if the inlet temperature is different from standard temperature, read the flow rate (Q) from the curve corresponding to the corrected DP.

Calculate the viscosity at the flowing temperature using the viscosity equation for the flowing gas. Then calculate the viscosity correction factor using

$$\mu_{cf} = \frac{\text{viscosity constant from curve/table}}{\text{flowing gas viscosity at flowing temperature}}$$

Multiply Q by the viscosity correction factor μ_{cf} . This product will give the flow rate of a particular gas at the actual flowing conditions.

3) At flowing inlet temperature equal to the standard temperature, read the curve/table directly in actual volumetric flow rate.

Table A-31031

Meriam Laminar Flow Element Pressure Correction Factor (any Gas) Base Pressure (Assigned Standard) 29.92 Inches Mercury Absolute

LAMINAR INLET PRESSURE INCH HG. ABS		LAMINAR INLET PRESSURE INCH Pcf.		LAMINAR INLET PRESSURE INCH HG. ABS.		LAMINAR INLET PRESSURE INCH Pcf.		LAMINAR INLET PRESSURE INCH HG. ABS.		LAMINAR INLET PRESSURE INCH Pcf.	
26.00	.8689	28.05	.9375	30.05	1.0043	32.10	1.0728	34.15	1.1413		
26.05	.8706	28.10	.9391	30.10	1.0060	32.15	1.0745	34.20	1.1430		
26.10	.8723	28.15	.9403	30.15	1.0076	32.20	1.0762	34.25	1.1447		
26.15	.8739	28.20	.9425	30.20	1.0093	32.25	1.0778	34.30	1.1458		
26.20	.8756	28.25	.9441	30.25	1.0110	32.30	1.0795	34.35	1.1480		
26.25	.8773	28.30	.9458	30.30	1.0127	32.35	1.0812	34.40	1.1497		
26.30	.8790	28.35	.9475	30.35	1.0143	32.40	1.0828	34.45	1.1514		
26.35	.8806	28.40	.9491	30.40	1.0160	32.45	1.0845	34.50	1.1530		
26.40	.8823	28.45	.9508	30.45	1.0177	32.50	1.0862	34.55	1.1547		
26.45	.8840	28.50	.9525	30.50	1.0193	32.55	1.0879	34.60	1.1564		
26.50	.8856	28.55	.9542	30.55	1.0210	32.60	1.0895	34.65	1.1580		
26.55	.8873	28.60	.9558	30.60	1.0227	32.65	1.0912	34.70	1.1597		
26.60	.8890	28.65	.9575	30.65	1.0243	32.70	1.0929	34.75	1.1614		
26.65	.8907	28.70	.9592	30.70	1.0260	32.75	1.0945	34.80	1.1631		
26.70	.8923	28.75	.9608	30.75	1.0277	32.80	1.0962	34.85	1.1647		
26.75	.8940	28.80	.9625	30.80	1.0294	32.85	1.0979	34.90	1.1664		
26.80	.8957	28.85	.9642	30.85	1.0310	32.90	1.0995	34.95	1.1681		
26.85	.8973	28.90	.9659	30.90	1.0327	32.95	1.1012	35.00	1.1697		
26.90	.8990	28.95	.9675	30.95	1.0344	33.00	1.1029	35.05	1.1714		
26.95	.9007	29.00	.9692	31.00	1.0360	33.05	1.1046	35.10	1.1731		
27.00	.9024	29.05	.9709	31.05	1.0377	33.10	1.1062	35.15	1.1747		
27.05	.9040	29.10	.9725	31.10	1.0394	33.15	1.1079	35.20	1.1764		
27.10	.9057	29.15	.9742	31.15	1.0411	33.20	1.1096	35.25	1.1781		
27.15	.9074	29.20	.9759	31.20	1.0427	33.25	1.1112	35.30	1.1798		
27.20	.9090	29.25	.9776	31.25	1.0444	33.30	1.1129	35.35	1.1814		
27.25	.9107	29.30	.9792	31.30	1.0461	33.35	1.1146	35.40	1.1831		
27.30	.9124	29.35	.9809	31.35	1.0477	33.40	1.1163	35.45	1.1848		
27.35	.9141	29.40	.9826	31.40	1.0494	33.45	1.1179	35.50	1.1864		
27.40	.9157	29.45	.9842	31.45	1.0511	33.50	1.1196	35.55	1.1881		
27.45	.9174	29.50	.9859	31.50	1.0528	33.55	1.1213	35.60	1.1898		
27.50	.9191	29.55	.9876	31.55	1.0544	33.60	1.1229	35.65	1.1915		
27.55	.9207	29.60	.9893	31.60	1.0561	33.65	1.1243	35.70	1.1931		
27.60	.9224	29.65	.9909	31.65	1.0578	33.70	1.1263	35.75	1.1948		
27.65	.9241	29.70	.9926	31.70	1.0594	33.75	1.1280	35.80	1.1965		
27.70	.9258	29.75	.9943	31.75	1.0611	33.80	1.1296	35.85	1.1981		
27.75	.9274	29.80	.9959	31.80	1.0628	33.85	1.1313	35.90	1.1998		
27.80	.9291	29.85	.9976	31.85	1.0645	33.90	1.1330	35.95	1.2015		
27.85	.9308	29.90	.9993	31.90	1.0661	33.95	1.1346	36.00	1.2032		
27.90	.9324	29.92	1.0000	31.95	1.0678	34.00	1.1363				
27.95	.9341	29.95	1.0010	32.00	1.0695	34.05	1.1380				
28.00	.9358	30.00	1.0026	32.05	1.0711	34.10	1.1397				

For values not shown in table, interpolate or use equation:

$$Pcf = \frac{P \text{ flow}}{P \text{ Base}} = \frac{P \text{ flow}}{29.92}$$

Pcf = Pressure Conversion Factor

P base = Assigned Base Pressure of 29.92 inches mercury absolute

P flow = Laminar Inlet Pressure, inches mercury absolute

The equation can be used up to and including two atmospheres absolute. It will be necessary to calibrate laminars for pressure exceeding above.

Table A-31986
Air Viscosity Correction Factors for ACFM Base Viscosity 181.87 Micropoise at 70°F

$$\text{Correction Factor} = \frac{181.7}{\mu g^*}$$

Note: These correction factors do not correct for volume changes due to temperature

Temp °F	+0	+1	+2	+3	+4	+5	+6	+7	+8	+9
50	1.03034	1.02877	1.02720	1.02564	1.02408	1.02253	1.02099	1.01945	1.01792	1.01639
60	1.01487	1.01336	1.01185	1.01035	1.00885	1.00736	1.00588	1.00440	1.00292	1.00146
70	1.0000	0.99854	0.99709	0.99564	0.99420	0.99277	0.99134	0.98992	0.98850	0.98709
80	0.98568	0.98428	0.98288	0.98149	0.98010	0.97872	0.97734	0.97597	0.97461	0.97325
90	0.97189	0.97054	0.96919	0.96785	0.96651	0.96518	0.96386	0.96253	0.96122	0.95991
100	0.95860	0.95729	0.95600	0.95470	0.95341	0.95213	0.95085	0.94957	0.94830	0.94704
110	0.94578	0.94452	0.94327	0.94202	0.94077	0.93953	0.93830	0.93707	0.93584	0.93462
120	0.93340	0.93219	0.93098	0.92977	0.92857	0.92737	0.92618	0.92499	0.92380	0.92262
130	0.92144	0.92027	0.91910	0.91794	0.91678	0.91562	0.91446	0.91331	0.91217	0.91103
140	0.90989	0.90875	0.90762	0.90650	0.90537	0.90425	0.90314	0.90203	0.90092	0.89981
150	0.89871	0.89761	0.89652	0.89543	0.89434	0.89326	0.89218	0.89110	0.89003	0.88896

Table A-32422
Air Temperature/Viscosity Correction Factors for SCFM Air Base
Temperature 70°F 181.7 Micropoise Reference NBS Circular 564

$$\text{Correction Factor} = \frac{529.67}{459.67 + ^\circ\text{F}} \times \frac{181.7}{\mu\text{g}^*}$$

$$\mu_{\text{air}} = \frac{14.58 \times \left(\frac{459.67 + ^\circ\text{F}}{1.8} \right)^{\frac{3}{2}}}{110.4 + \left(\frac{459.67 + ^\circ\text{F}}{1.8} \right)}$$

Temp °F	+0	+1	+2	+3	+4	+5	+6	+7	+8	+9
50	1.0707	1.0670	1.0633	1.0596	1.0559	1.0523	1.0487	1.0451	1.0415	1.0379
60	1.0344	1.0308	1.0273	1.0238	1.0204	1.0169	1.0135	1.0101	1.0067	1.0033
70	1.0000	.9966	.9933	.9900	.9867	.9834	.9802	.9770	.9737	.9705
80	.9674	.9642	.9611	.9579	.9548	.9517	.9486	.9456	.9425	.9395
90	.9365	.9335	.9305	.9275	.9246	.9216	.9187	.9158	.9129	.9100
100	.9072	.9043	.9015	.8987	.8959	.8931	.8903	.8875	.8848	.8820
110	.8793	.8766	.8739	.8712	.8686	.8659	.8633	.8606	.8580	.8554
120	.8528	.8503	.8477	.8452	.8426	.8401	.8376	.8351	.8326	.8301
130	.8276	.8252	.8227	.8203	.8179	.8155	.8131	.8107	.8083	.8060
140	.8036	.8013	.7990	.7966	.7943	.7920	.7898	.7875	.7852	.7830
150	.7807	.7785	.7763	.7741	.7719	.7697	.7675	.7653	.7632	.7610

* When flowing gas other than air, use the viscosity in micropoise of the gas at flowing temperature in the Correction Factor equation.

Table A-35700
Temperature Correction Factor
Base Temperature = 70°F

$$\text{Tcf} = \frac{529.67}{(459.67 + ^\circ\text{F})}$$

Maintenance

Accumulation of dirt in the capillaries of the laminar element will affect the accuracy. When in doubt, hold the laminar in front of a high intensity light, sighting through the capillaries. Any dirt will be apparent. Loose dirt can be blown out with shop air (no more than 100 PSI) in reverse direction of flow. Shop air must be clean and dry. Brushing or rubbing the ends of the matrix element is not recommended because the matrix can be deformed, altering the calibration. Unless the customer has the facilities and primary standards to check calibration after cleaning, we recommend returning the unit to Meriam for cleaning and calibration.

Temp °F	+0	+1	+2	+3	+4	+5	+6	+7	+8	+9
50	1.0392	1.0372	1.0352	1.0332	1.0311	1.0291	1.0271	1.0252	1.0232	1.0212
60	1.0192	1.0173	1.0153	1.0134	1.0115	1.0095	1.0076	1.0057	1.0038	1.0019
70	1.0000	0.9981	0.9962	0.9944	0.9925	0.9906	0.9888	0.987	0.9851	0.9833
80	0.9815	0.9797	0.9778	0.976	0.9742	0.9725	0.9707	0.9689	0.9671	0.9654
90	0.9636	0.9619	0.9601	0.9584	0.9567	0.9549	0.9532	0.9515	0.9498	0.9481
100	0.9464	0.9447	0.943	0.9414	0.9397	0.938	0.9364	0.9347	0.9331	0.9314
110	0.9298	0.9282	0.9265	0.9249	0.9233	0.9217	0.9201	0.9185	0.9169	0.9153
120	0.9137	0.9122	0.9106	0.909	0.9075	0.9059	0.9044	0.9028	0.9013	0.8998
130	0.8982	0.8967	0.8952	0.8937	0.8922	0.8907	0.8892	0.8877	0.8862	0.8847
140	0.8833	0.8818	0.8803	0.8789	0.8774	0.876	0.8745	0.8731	0.8716	0.8702
150	0.8688	0.8674	0.8659	0.8645	0.8631	0.8617	0.8603	0.8589	0.8575	0.8561

Troubleshooting

Problem	Probable Cause	Remedy
Low or High DP Indication	Insufficient or improperly sized straight pipe downstream and/or upstream of LFE.	Use 10 diameters of straight pipe upstream and 5 diameters of straight pipe downstream of LFE. Pipe size should be same as LFE outlet size, e.g. ½" NPT on LFE means 10 diameters of ½" pipe.
	One or both differential pressure connection taps plugged.	Clean or check instrument connecting line.
	If pulsation dampener is used, check stones (Model 50 MR2 and 50 MC2 only).	If plugged, replace with matched pair (Meriam part #A-31650).
	Leak in line between LFE and readout device.	Detect and repair.
	Large-volume and/or unequal-volume connecting lines to readout device.	Use small-volume and equal volume connecting lines to readout device. See Installation on page 4.
Pulsating / Irregular Reading	Piping reducers at inlet and/or outlet.	Do not use reducers immediately before or after LFE.
	Irregular flow pattern entering LFE.	Use at least 10 diameters of straight pipe upstream of LFE.
	Leak in system line.	Detect and repair.

When you decide to have your LFE cleaned, please be aware of the various capabilities of calibrating LFE's at Meriam. Every calibration includes: 6-8 calibration points [differential pressure 1"-8"H₂O], a data sheet with raw and reduced data, calibration curve, and instruction manual. The procedure numbers are noted in (parentheses).

Calibrations	NIST Traceable Certificate	Accuracy
(% Reading)		
<input type="checkbox"/> Clean per (A33555) and calibrate per (A35822) Working-Master	X	±0.72% R
<input type="checkbox"/> Clean per (A33555) and calibrate per (A35822) Master-Master	X	±0.54% R
<input type="checkbox"/> As Received calibration (A35822/A34777), clean, and calibrate [WM]	X	±0.72% R
<input type="checkbox"/> As Received calibration (A35822/A34777), clean, and calibrate [MM]	X	±0.54% R
<input type="checkbox"/> Accredited calibration ISO/IEC 17025 (contact Sales for details)	X	±0.64% R
<input type="checkbox"/> Nuclear or safety application (A33544)	X	±0.72% R
<input type="checkbox"/> Subcontracted per (A35352)	X	±0.50% R

Options

- 2 additional calibration points beyond full scale- up to 12"H₂O
- Additional calibration points beyond full scale at the following settings _____.
- Additional calibration points below 1"H₂O at the following settings _____.
- Oxygen cleaning per (A50558)
- Calibrating the LFE with differential pressure transmitter
- Hydrostatic leak testing per (A33559)
- Pneumatic pressure test per (A70763)

The standard reference unit for flow rate is (cfm) cubic feet per minute. The additional units available are:

- Liters
- Cubic Centimeters
- Meters
- Pounds (include flowing temperature and pressure)
- Kilograms (include flowing temperature and pressure)
- Other _____

Time constants:

- Second
- Minute
- Hour

The standard reference for differential pressure is inches of water at 4°C. The additional units available are:

- Millimeters of water @ 4°C
- Centimeters of water @ 4°C
- Pascals
- Kilopascals
- Other _____

A second data sheet and calibration curve using the listed units will be included with the calibration

LFE Dimensions

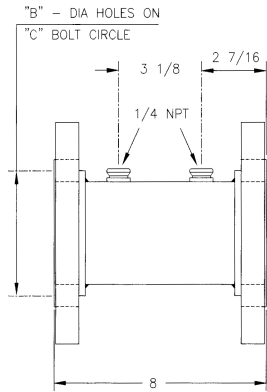

MODEL 50MY15--(SIZE)
SS BODY & FLANGE
SS HALF COUPLINGS

SIZE	A	B-DIA	C	SIZE	A	B-DIA	C
2	1 1/2	4-3/4	5 1/2	8	8-7/8	11 3/4	
3	4-3/4	6		10	12-1	14 1/4	
4	8-3/4	7 1/2		12	12-1	17	
6	8-7/8	9 1/2		16	16-1/8	21 1/4	

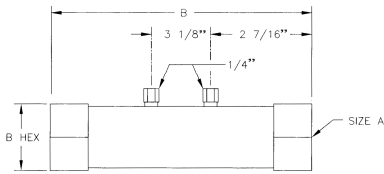

MODEL 50MW20--(SIZE)
SS BODY
SS HALF COUPLINGS

SIZE	A	B
1"	1 5/8"	
1 1/2"	2 1/4"	
2"	2 3/4"	

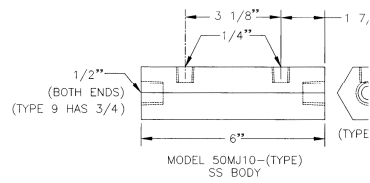

MODEL 50MJ10--(TYPE)
SS BODY

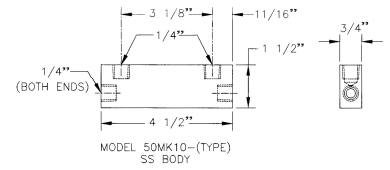

MODEL 50MK10--(TYPE)
SS BODY

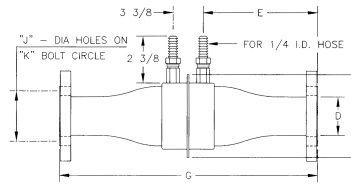

MODEL 50MR2--(SIZE)
ALUMINUM BODY
ALUMINUM HOSE CONNECTIONS
ALUMINUM FLANGES

MODEL	SIZE	D	E	F	G	J-DIA	K
50MR2-2	2	6 1/16	5 1/4	15 1/2	4-3/4	4 3/4	
50MR2-4	4	10 13/16	8 1/2	25	8-3/4	7 1/2	
50MR2-6	6	13 9/16	12	30 1/2	8-7/8	9 1/2	
50MR2-8	8	16 15/16	16 3/4	37 1/4	8-7/8	11 3/4	

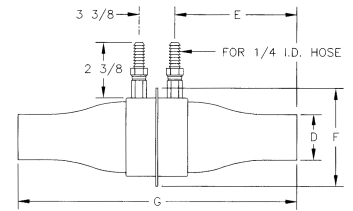

MODEL 50MC2--(SIZE)
ALUMINUM BODY
ALUMINUM HOSE CONNECTIONS

MODEL	SIZE	D	E	F	G
50MC2-2	2	5 9/16	5 1/4	14	1 1/2
50MC2-4	4	10 5/16	8 1/2	24	
50MC2-6	6	13 5/16	12	30	
50MC2-8	8	16 5/16	16 3/4	36	

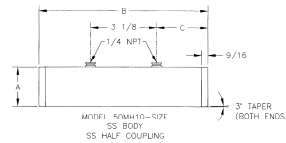

MODEL 50MH10--(SIZE)
SS BODY
SS HALF COUPLING

SIZE	PIPE O.D. A	B	C	SIZE	PIPE O.D. A	B	C	SIZE	PIPE O.D. A	B	C
1	1 5/16	8	2 7/16	3	3 1/2	8	2 7/16	8	8 5/8	12	4 7/16
1 1/4	1 21/32	8	2 7/16	4	4 1/2	8	2 7/16	10	10 3/4	12	4 7/16
1 1/2	1 29/32	8	2 7/16	6	5 9/16	8	2 7/16	12	12 3/4	12	4 7/16
2	2 3/8	8	2 7/16	8	6 5/8	8	2 7/16	16	16	12	4 7/16