



meriam
process technologies

F/N 3405:440-1

a Scott Fetzer company



 **-CAL mA**

Handheld single function
mA current indicator - simulator

User's Manual

INTRODUCTORY NOTE

ATTENTION : THIS MANUAL MUST BE REFERRED TO FOR INSTRUMENTS WITH SERIAL NUMBER FROM 002075 FORWARD.

*This manual includes all the information you need to install, operate and maintain the **M-CAL mA** Calibrator and its accessories.*

***Meriam** has used the best care and efforts in preparing this book and believes the information in this publication are accurate. **Meriam** products are subjected to continuous improvement; these improvements could require changes to the information of this manual.*

***Meriam** reserves the right to change such information without notice.*

*No part of this document may be stored in a retrieval system, or transmitted in any form, electronic or mechanical, without prior written permission of **Meriam Process Technologies**.*

***M-CAL mA Calibrator** uses sophisticated analog and digital technologies. Any maintenance operation must be carried out by qualified personnel ONLY. **Meriam** supplies instructions and operative procedures for any operation on the instrument. We recommend contacting our technicians for any support requirements.*

***M-CAL mA** is fully tested in conformity with the Directive No. 89/336/CEE Electromagnetic Compatibility. **Meriam** shall not be liable in any event, including technical and publishing errors or omissions, for any incidental and consequential damages, in connection with, or arising out of the use of this book.*



All right reserved
Copyright © 2005

MERIAM PROCESS TECHNOLOGIES
10920 Madison Avenue
Cleveland, Ohio 44102

TELEPHONE: (216) 281-1100
FAX: (216) 281-0228
E-mail: meriam@meriam.com
Web Site: www.meriam.com

INDEX

1	GENERAL PERFORMANCE	6
1.1	Model codes-----	7
1.2	Specifications-----	8
2	GENERAL FEATURES	10
2.1	Flexibility-----	10
2.2	Self calibration-----	10
2.3	Keyboard-----	10
2.4	Display-----	10
2.5	Generator mode (Passive external circuit - no power supply on the external loop)-----	10
2.6	Simulator mode (Active external circuit - power supply on the external loop)-----	10
2.7	Measuring mode - normal-----	10
2.8	Measuring mode - power (Passive external circuit)-----	11
2.9	Power supply mode-----	11
2.10	IN-OUT technical unit mode (%)-----	11
2.11	Scale factor-----	11
2.12	Square root-----	11
2.13	Average mode-----	11
2.14	Hold function-----	11
2.15	Case-----	11
3	PHYSICAL DESCRIPTION	12
4	FUNCTIONAL DESCRIPTION	13
4.1	Power supply-----	13
4.2	Operation of keyboard-----	13
4.3	Input circuit-----	14
4.4	Microprocessor-----	14
4.5	Firmware-----	14
4.6	Digital display-----	14
4.7	Digital to analog converter-----	15
4.8	Rechargeable Battery Models; operation from line source-----	15
5	UNPACKING	16
6	PRE-OPERATIONAL CHECK	16
7	ELECTRICAL CONNECTIONS (INPUT-OUTPUT)	16
7.1	Wiring practice-----	17
8	OPERATIONS & APPLICATIONS	19
8.1	Batteries-----	19
8.2	Battery charger; power supplied from power line ac-----	17
8.3	Power "ON"-----	17
8.4	Battery voltage indication-----	18
8.5	Operating mode set-up-----	18
8.5.1	IN / OUT function selection-----	18
8.5.2	Parameter selection-----	19
8.5.3	Average readings-----	19
8.5.4	Hold function-----	20
8.5.5	IN / OUT data memories-----	20
8.5.6	STEP increment-----	20
8.5.7	"Scale factor" mode-----	21
8.5.8	mA - % selection-----	21
8.6	Faulty operating conditions-----	21

9	MAINTENANCE	23
9.1	Safety recommendations-----	23
9.2	Spare parts and accessories-----	23
9.3	Storage-----	23
10	CERTIFICATES	24
10.1	Warranty-----	24
10.2	Conformity-----	24
	APPENDIX	25
A1	EMC Conformity-----	26
A2	Declaration of Conformity-----	27

1 GENERAL PERFORMANCE

The portable indicator – simulator **M-CAL mA** is an instrument designed to perform, in a modern and practical way, all the most popular process current check-outs and calibration, both in laboratory and field work.

The current signal levels are those normally used on instruments, components and systems for industrial process control.

Accurate, compact, rugged, and easy to use the M-CAL mA represents the ideal solution for measurement and simulation inside both passive and active external circuits with five different modes of operation:

- **Generator mode**
- **Simulator mode**
- **Normal measuring mode**
- **Loop powered measuring mode**
- **24V dc power supply**

The microprocessor technology provides high accuracy on extended ranges and carries out mathematical computations (average, scale factor, square root) to simplify operator use.

The selection of operating mode is made on a polycarbonate membrane keyboard which assures up to one million operations per key.

The measured or the simulated value is indicated on a high quality LCD dot matrix display providing good contrast even in poor light conditions.

A menu-driven set-up allows the generation of a single value, and the storage of three values with manual recall.

A manual repeat measurement is also possible (<**STEP**> key).

The case, made of shock-resistant and self-extinguishing ABS, is ergonomically designed for easy and practical operations.

Model options for four alkaline AA batteries (1.5 V) or four Ni-MH rechargeable batteries AA (1.2 V 0.7A/hour) are available. The Ni-MH models come with an external battery charger / AC power supply as a standard accessory. NOTE: Alkaline powered models are not compatible with AC power.

1.1 Model codes

M-CAL mA Part No. 3405 – A – B

Basic configuration of the instrument includes a soft carrying case with belt loop and a user's manual.

Table A **Batteries/line charger**

0	Alkaline /none
1	Ni-MH rechargeable with external charger / AC power supply (Specify plug type with order)

Plug Types:

- Ni-MH/120VAC 50/60 Hz – USA plug
- Ni-MH/230VAC 50/60 Hz – Schuko plug
- Ni-MH/230VAC 50/60 Hz – UK plug
- Ni-MH/230VAC 50/60 Hz – European plug
- Ni-MH/100VAC 50/60 Hz – USA/Japan plug

Table B **Report of Calibration**

0	No NIST certificate
1	NIST certificate + data

1.2 Specifications

- **IN / OUT parameter**
mA and %
- **Ranges:**
from 0.00 to 22.00 mA
from 4.00 to 20.00 mA
- **Resolution:**
0.01 mA or 0.1%
- **Limits of error:**
 $\pm 0.05\%$ of the reading +10 μ A
(The limits of error are defined at the ambient temperature of 23°C \pm 2°C for 30 days without the use of the autocalibration program)
- **mA to % conversion :**
linear or square
- **Common mode rejection:**
>130 dB at 50/60 Hz
- **Normal mode rejection:**
>60 dB at 50/60 Hz
- **Temperature stability:**
span: $\pm 0.0125\%$ of the reading/ $^{\circ}$ C
zero $\pm 2 \mu$ A/ $^{\circ}$ C
- **Internal shunt resistance:**
< 50 Ω
- **Output impedance:**
MA x 1 k Ω (20 mA with internal feeder 24V dc)
- **Power supply for external loop:**
24V dc with maximum current of 22 mA
- **Display:**
high contrast dot matrix alphanumeric LCD display (7x5 dots per character – 16 characters)
- **Display contrast:**
4 step keyboard setting
- **Scale factor:**
Zero and span programmable within -10000 and +10000
- **Square root:**
in combination with scale factor (display limits 0 and +2500)
- **Calibration:**
automatic procedure
- **Input protection:**
up to 150V with special fuse + electronic protection
- **Power supply:**
4 AA alkaline batteries or Ni-MH rechargeable batteries 1.2V 0.7 A/hour
- **Battery life:**
Ni-MH 8 hours, Alkaline 16 hours continuous operation
- **Battery level indication:**
low battery symbol
- **Battery charger module:**
supplied as a standard accessory
- **Recharge time:**
8 hours to 90% with instrument switched -OFF-
- **Batteries voltage:**
4.8 V (nominal)
- **Program release identification:**
release code on the display

- **Operating environment temperature range:**
from -5°C to +50°C
- **Storage temperature range:**
from -20°C to 60°C
- **Case:**
ABS
- **Dimensions:**
210 x 96 x 40 mm
- **Weights:**
net 0.9 Kg
gross with packaging 1.2 Kg

2 GENERAL FEATURES

2.1 Flexibility

Advanced flexibility of performance has been achieved using microprocessor technology. The indicator-simulator **M-CAL mA** is a complete system for check outs, measurements and calibrations built into a single compact portable instrument. The simulated or measured values can be directly indicated in electrical units (mA) or technical units (%).

2.2 Self calibration

The hardware-firmware design allows for an automatic calibration of the instrument. A precise source of 20mA dc is the only required standard reference. The calibration procedure is protected by a security code.

2.3 Keyboard

A tactile polycarbonate membrane keyboard, with a working life of one million operations per key, seals the internal electronics from the surrounding environment. It allows the selection of the operation mode and the setting of simulation value with fast and slow rate of change. Contact closure of membrane keys is acknowledged as a coded signal directly by the microprocessor

2.4 Display

The high quality alphanumeric LCD display (7x5 dot matrix per character – 16 characters) allows easy readings even in poor light conditions. The operation mode [measurement (IN) or simulation (OUT)], the technical unit and the signal value are simultaneously indicated.

2.5 Generator mode (OUT – Passive external circuit)

The instrument generates a current signal (ranging from 0.00 mA to 22.00 mA dc) into a passive circuit to calibrate recorders, controllers, indicators, actuators, etc.

2.6 Simulator mode (OUT – Active external circuit)

Simulates the output of a 2-wire transmitter (0.00 to 22.00 mA dc) in a loop with external power.

2.7 Measuring mode (IN) – normal

Reads dc current directly in milliamperes or in technical units (%)

2.8 Measuring mode – power (IN – Passive external circuit)

The instrument provides 24V dc power for operating a 2-wire transmitter and simultaneously reads the loop current in percent (-25.0 to +100,0%) or milliamperes (0.00 to 20.00 mA).

2.9 Power supply mode (OUT)

The instrument can be used as a loop power source (24V dc with a maximum current of 22 mA).

2.10 IN-OUT technical unit mode (%)

The instrument converts the voltage signal into %, or vice-versa, with the following linear relation:

0	4	12	20
-25.00%	0.00%	+50.00%	+100.00%

2.11 Scale factor

Easy menu-driven set-up to read or simulate electrical signal value in terms of technical units (i.e. bar, % CO, RH, etc.).

2.12 Square root

Can be programmed during the set up procedure (linear ranges only) e.g. to obtain direct readings of flow from a dP transmitter signal.
The display limits are 0 to +2500.

2.13 Average mode

For the measurements of unstable input signals by a progressive averaging of a programmable number of conversions (approximately 10 seconds)

2.14 Hold function

To freeze on the display the last measured value.

2.15 Case

The case, made of shock-resistant and self-extinguishing ABS, is ergonomically designed for easy practical operation. The instrument is supplied in a soft protective case with belt strap for easy transportation.

3 PHYSICAL DESCRIPTION

The **M-CAL mA** portable calibrator consists of a rugged and compact case, a mother board with all base functions, a tactile polycarbonate membrane keyboard, an LCD display and a group of four AA alkaline or four AA Ni-MH rechargeable batteries.

The battery container is located on the back of the case and is accessible by sliding and removing the plastic cover.

The case has been designed and manufactured using modern CAD/CAM techniques giving consideration to manufacturing process and ergonomic characteristics for easy operation and transportation.

The two halves of the case are joined together by five metal screws located on the back side.

The soft case, with belt loop, assures better protection of the instrument against knocks or scratches.

4 FUNCTIONAL DESCRIPTION

The block diagram of the **M-CAL mA** portable calibrator is shown in the figure below:

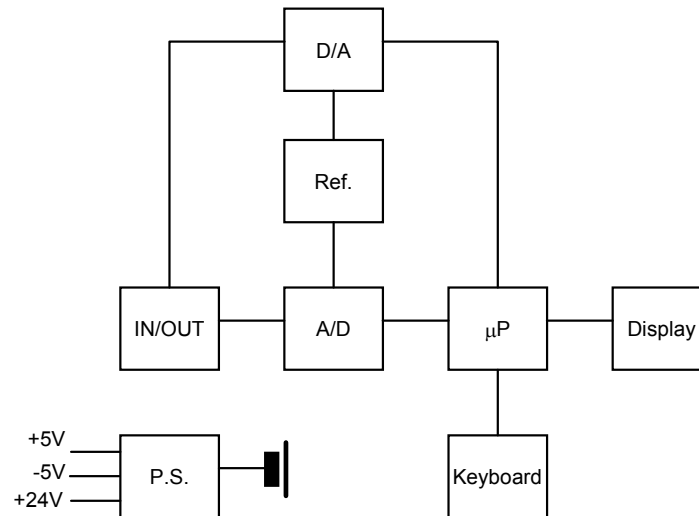

The functional blocks of the instrument are as follows:

- **power supply**
- **microprocessor (central unit + memory)**
- **input circuit**
- **LCD display**
- **membrane keyboard**
- **output circuit**

4.1 Power supply

The instrument is powered as specified by the order, by four internal AA alkaline (1.5V) or four AA Ni-MH (1.2 V, 0.7 A/hour) rechargeable batteries. Ni-MH batteries can be recharged using the external charger module supplied as a standard accessory with Ni-MH rechargeable models.

A section of the power supply circuit enables following voltages function :

- + 5 V logic and analog circuits
- 5 V analog circuits

A second section of the power supply circuit, configured as a voltage multiplier generates a voltage level of 24 V dc to interface a maximum resistance of 1000 ohm with a current simulation of 20mA .

4.2 Operation of keyboard

The front panel is a tactile polycarbonate membrane keyboard, and has a working life of one million operations per key. The contact closure of the membrane keyboard keys is acknowledged as a coded signal by the microprocessor which recognizes the operator's instruction.

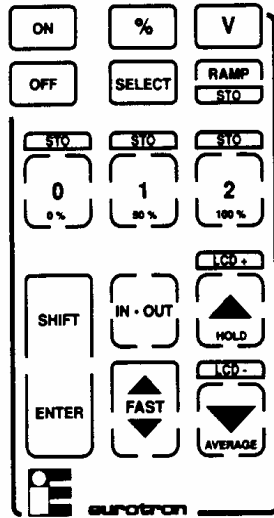

ON	power –ON- key
OFF	power –OFF- key
▲ / ▼	simulation value cursors (1 L.S.D. step)
STO	memory load keys
STEP	step value setting on ramp simulation
0, 1, 2	IN – OUT memories
SELECT	set-up procedure
AVERAGE	average measurements
IN/OUT	IN-OUT mode selection
LCD±	display contrast adjustment
HOLD	last measured value display hold
%	technical unit selection
mA	electrical unit selection
ENTER	memory load key
SHIFT	key secondary function
FAST	cursor accelerator (L.S.D. x 100); use in conjunction with ▲/ ▼ keys

A “bip” sound indicates that the instrument has received and acknowledged the operators instruction.

4.3 Input circuit

This input circuit is based on two shunt resistors to convert the current signal to voltage signal. The voltage signal is converted from analog to digital with a dedicated integrated circuit.

4.4 Microprocessor

The microprocessor handles all the logic functions of the instrument, drives the digital display and acknowledges all operator instructions.

The heart of the circuit is a single-chip microcomputer (68HC705C8) that utilizes HCMOS technology to provide the low power characteristics and high noise immunity of CMOS plus the high speed operation of HMOS.

The above circuit incorporates a watchdog feature to reset normal operation in case of program blocks caused by external high energy interferences and two serial communication subsystems (SCI and SPI).

4.5 Firmware

The operating system firmware handles all logic instructions to the internal peripheral circuits and performs the computation of scale factor and square root.

The application system firmware is resident on the non-volatile memory (EEPROM) on the microprocessor chip. It is used to store the installation parameters (autocalibration data, programs data, etc.)

4.6 Digital display

The digital display, mounted on an auxiliary board, uses high contrast LCD technology .

The character generation is by a dedicated secondary microprocessor driven by the bus of the mA in microprocessor.

The 16 characters are displayed with a 7 x 5 dot mA trix.

4.7 Digital to analog converter

The digital to analog is based on a special reconfiguration of the A/D integrated circuit. A section of the analog switch and output amplifier are also operative.

4.8 Rechargeable Battery Models; operation from line source

A auxiliary charger / power supply module is supplied as a standard accessory with all Ni-MH rechargeable battery models. The charger / power supply module allows operation from 110-120 or 220-240 V ac 50/60 Hz depending on the plug type specified on the order.

Calibrators with rechargeable batteries can be operated directly from a line source through the charger / power supply module.

The plastic case of the battery charger / power supply incorporates the line voltage plug and cable for connection to the instrument. The charger circuit is designed with an insulating transformer and a voltage stabilizer circuit. The step-down transformer reduces the power line (110-120 Vac or 220-240 Vac nominal) to a value of 10 Vac.

The above voltage is full wave rectified, filtered and stabilized.

The output voltage of 6.45 Vdc is the ideal value to recharge internal Ni-MH batteries.

5 UNPACKING

Remove the instrument from its packing case and remove any shipping ties, clamps, or packing materials. Carefully follow any instructions given on any attached tags.

Inspect the instrument for scratches, dents, damage to case corner etc. which may have occurred during shipment.

If any mechanical damage is noted, report the damage to the shipping carrier and then notify **MERIAM** directly or it's nearest agent, and retain the damaged packaging for inspection.

A label located on the back of the case indicates the serial number of the instrument.

Refer to this number for any inquiry for service, spare parts supply, application or technical support requirements.

6 PRE-OPERATIONAL CHECK

The instrument is powered by four AA alkaline or four AA Ni-MH rechargeable batteries.

The external battery charger, supplied as standard with Ni-MH rechargeable models, may be ordered for either 110-120 Vac or 220-240 Vac power source.

To modify the charger's power voltage follow the instructions in par. 8.2.

Before the first use of the instrument carefully verify the nominal voltage value of the charger; in case of modification do not forget to correct the pertinent label.

The instrument should be used in environments where the temperature does not exceed the specified limits (from -5°C to $+50^{\circ}\text{C}$) and where the relative humidity is lower than 95%.

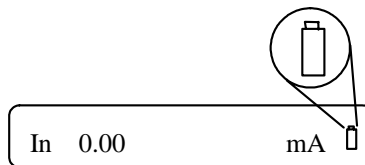

In case of "low" battery condition (voltage lower than $4.5\text{ V} \pm 0.1\text{ V}$) the display will show the appropriate symbol.

An empty symbol means that the battery package has enough energy to operate for approximately 30 additional minutes.

A black symbol means that batteries charge is below the minimum acceptable level : operation of the instrument is no longer possible. In this condition the batteries must be either replaced (if alkaline battery model) or recharged (if Ni-MH rechargeable battery powered).

WARNING.

**FOR MODELS SUPPLIED WITH Ni- MH RECHARGEABLE BATTERIES...
DO NOT USE NORMAL ALKALINE BATTERIES!!!**

**ALKALINE BATTERIES, WHEN CONNECTED TO A DC VOLTAGE SUPPLY, UNDERTAKE AN OVERHEATING PROCESS WITH
A RISK OF EXPLOSION.**

7 ELECTRICAL CONNECTIONS (input-output)

Make sure that IN/OUT terminals are connected with the correct polarity.

7.1 Wiring practice

Although the **M-CAL mA** portable calibrator is designed to be insensitive to transients or noise, the following recommendations should be followed to reduce ac pick up in the signal leads and to ensure optimum performance.

The input leads should not be run near ac line wiring, transformers or heating elements.

Input/output leads should, if possible, be twisted and shielded with the shield grounded at the end of the cable.

When shielded cables are used the shield must be connected to the positive terminal.

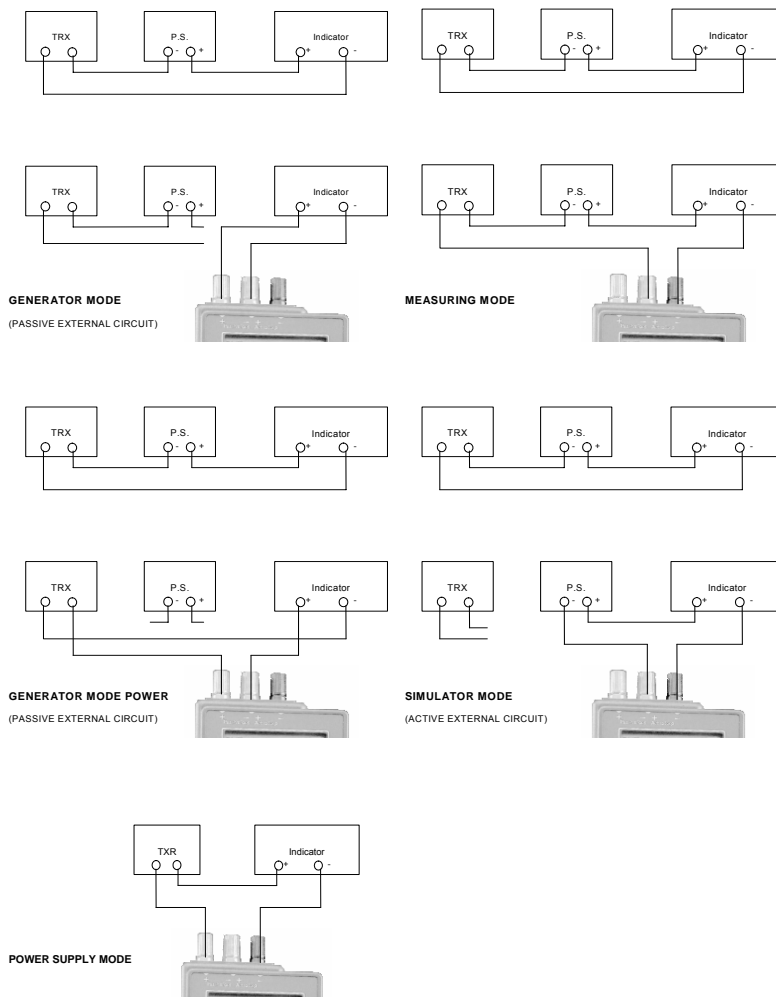

The fig.7.1 shows some examples of input/output wiring and connections.

8 OPERATIONS & APPLICATIONS

The **M-CAL mA** portable calibrator has been factory calibrated before shipment. During start-up the operator should only select and load the pertinent application parameters as described in the following paragraphs.

8.1 Batteries

Alkaline battery models are powered by four AA alkaline batteries shipped installed in the unit and come ready to use out of the package.

Ni-MH rechargeable models are shipped with batteries at an average level of charge. After unpacking, a full charge of the batteries is recommended. Connect the unit ("OFF" condition) to the charger module for a minimum of 12 hours. The Ni-MH rechargeable batteries do not suffer when used in cyclic operations. Cyclic operation is understood as a method of operation by which the battery is continually charged and discharged.

Note that a rechargeable battery, at its lower limit of charge, risks a non-uniform cell polarization: this condition makes it difficult to recharge with the charger supplied. Avoid leaving the instrument with installed rechargeable batteries totally or partially discharged for a long period of time without recharging. To charge the batteries, use only the original supplied charging module. The module incorporates protection and current limiting devices not normally found in other commercial chargers.

8.2 Battery charger; power supplied from power line ac

The external battery charger / power supply is configured, before shipment, for a mains supply of 110-120 V ac or 220-240 Vac, per the order specification.

The nominal voltage value is indicated on the front label of the charger; if the power supply voltage has to be modified, correct the indication on the front label.

To replace the power plug loosen the three bottom screws.

To modify the power supply voltage place the jumper, mounted on the circuit board of the charger, as indicated in figure:

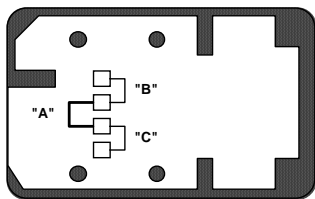

Jumper A
power line at 220-240 V 50/60 Hz

Jumpers B and C
power line at 110-120 V 50/60 Hz

8.3 Power "ON"

ATTENTION: ALL VALUES IN THE FOLLOWING FIGURES ARE ONLY LISTED AS EXAMPLES ONLY.

During set-up and load memory remember that the instructions of the manual related to key operation have the following meaning:

<A> + Press the <A> key and keeping the pressure on the key, press then the key
<A>, Press in sequence first the <A> key and then the key.



To power the instrument actuate the <ON> key (fig. 8.3.A); the indication of fig. 8.3.B will appear for a few seconds.



Fig. 8.3B

With power –ON- , the instrument will run an autodiagnostic routine for the self-checking of critical circuits and components.

A positive check will be shown with the indication of fig. 8.3.C for about one second,

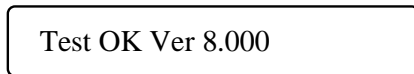

Fig. 8.3C

The number on the right side of the display indicates the version of the program installed on the instrument.

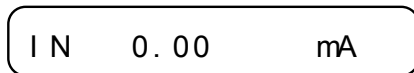

Fig. 8.3D

The instrument will go to the previously selected operating mode, i.e. as per fig. 8.3.D.

Faulty conditions will be indicated as described in par. 8.8.

8.4 Battery voltage indication.

During normal operating modes (measure or simulation) “low battery” condition will be shown as per fig. 8.4.A

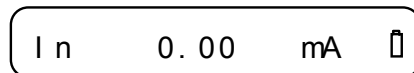

Fig. 8.4A

An empty symbol means that the battery has enough energy for about 30 minutes of operation.

A black symbol means that the battery charge level is below the minimum: alkaline batteries must be replaced or Ni-MH rechargeable batteries must be recharged for a full period of 12 hours.

8.5 Operating mode set-up

To select the required operating mode follow the procedures indicated below.

8.5.1 IN / OUT function selection



Switch the instrument –ON

After diagnostic routine, the calibrator will be forced into the “IN” function with the active parameter previously selected (i.e. with the indication of fig.8.5.1.B).

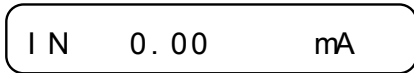

Fig. 8.5.1B

Press <IN/OUT> key to select the simulation mode with an indication as per fig. 8.5.1.C.

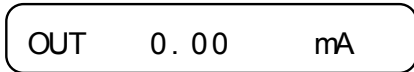

Fig. 8.5.1C

Press the <▲> or <▼> keys to adjust the simulation value.

A single touch on one of the two <▲> and <▼> keys will adjust the simulated value of one least significant digit.

A continuous touch will cause repetitive increments of the simulated value. The speed of variation can be accelerated by pressing <FAST> + <▲> or <FAST> + <▼> keys; a single touch will be equivalent to the third significant digit (L.S.D.A. x 100)

8.5.2 Parameter selection

To select the electrical parameter in measuring or simulation mode, follow the procedure indicated below:

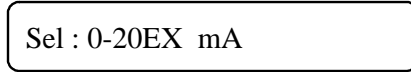
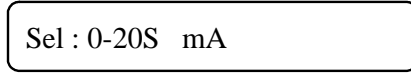
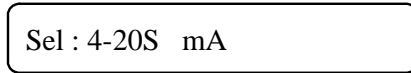
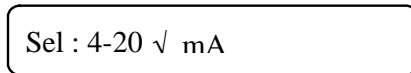
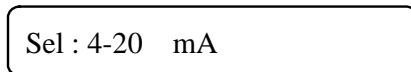

- ◆ Switch the instrument –ON–.
- ◆ Press the <SELECT> key; the display will show one of the menu pages, indicated in figure.
- ◆ Press <▲> or <▼> key to select the appropriate page.
- ◆ Press the <SELECT> key to invalidate the new instruction or the <ENTER> key to load the selection in the memory; the instrument will return to the previous function with the new selected mode (IN or OUT).

Key: 4-20 mA = linear
 4-20[√] mA = square root
 4-20S mA = scale factor proportional to 4-20 mA
 0-20S mA = scale factor proportional to 0-20 mA
 0-20EX mA = scale factor exponential to 0-20 mA

8.5.3 Average readings

The use of the “Average” function is advised with unstable input signals. The average represents a progressive integration of the input signal on the last 32 conversions (approximately 10 seconds).

Select the measuring mode (-IN-)

Press the <AVERAGE> key to enable the “Average” mode
 The display will show a reading as in fig. 8.5.3.A

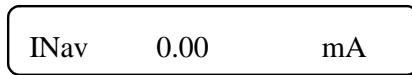

Fig. 8.5.3A

To disable the "Average" mode press again the **<AVERAGE>** key;

8.5.4 Hold function

The hold function is used to freeze on the display the last measured value.

Select the measuring mode (-IN-)

Press the **<HOLD>** key to enable the "hold" mode.
The display will shown a reading as in fig. 8.5.4.A.

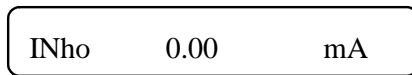

Fig. 8.5.4A

To disable the "hold" function, press again the **<HOLD>** key

8.5.5 IN / OUT data memories

The availability of a 3-step memory represents an important feature whether in simulation or in measurement modes.

In the measurement mode it can be useful to store three input values pertinent to special test conditions.

In the simulation mode, the permanent availability of three calibration values can be useful, e.g. during the calibration of the scale of a recorder.

Either in measuring (IN) or simulation (OUT) mode to load memory press keys:

<SHIFT> + <0>

<SHIFT> + <1>

<SHIFT> + <2>

The memory loaded values can be manually recalled by pressing the pertinent **<0>** or **<1>** or **<2>** key.

The mA signal stored values will be kept in the memory also when the instrument is switched -OFF-.

The technical unit stored values can be reprogrammed but the new value is automatically deleted when the instrument is switched -OFF-.

8.5.6 STEP increment

In the simulation mode the instrument provides a step variation feature to check e.g. the dead band of a potentiometric recorder.

- Switch the instrument -ON-.
- Select the simulation (OUT) mode with the **<IN/OUT>** key.
- With **<▲>** and **<▼>** keys adjust the indication to obtain the required step value.
- Press **<ENTER>** + **<STEP>** keys to load the step value in the memory.

- The simulated value will be incremented by a repetitive value each time the <STEP> key is pressed.

8.5.7 “Scale factor” mode

The “scale factor” mode is a method to read or to simulate electrical signal values in terms of technical units. This mode is especially useful for the calibration of a potentiometric recorder with scale from 0.0 mbar to 400.0 mbar corresponding to an electrical input linear signal from 4 to 20 mA .

- Press the <SELECT> key and scroll the menu pages with <▲> or <▼> key to obtain 0-20 S or 4-20 S.
Press the <ENTER> key to obtain the indication in fig. 8.5.7.A.

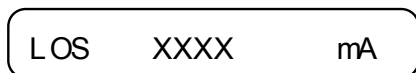

Fig. 8.5.7°

- Adjust with <▲> and <▼> keys the required zero scale value and press the <ENTER> key to load memory.
The display will show the indication in fig. 8.5.7.B.

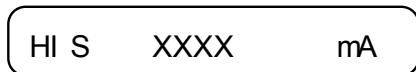

Fig. 8.5.7B

- Adjust the required technical unit full scale value and press the <ENTER> key to load memory.
The instrument will return to the measuring or simulation mode.
- To convert the technical unit into electrical unit, or vice versa, press the <mA > or <%> key.

8.5.8 mA - % selection

- With the instrument in operation, either in measuring or simulation mode, press the pertinent key to convert the electrical unit to technical unit (%) or vice versa.
The relation is linear as follows:

-25.0%	0.00 mA
0.0%	4.00 mA
+50.0%	12.00 mA
+100.0%	20.00 mA

8.6 Faulty operating conditions

During start up, measuring and simulation modes, faulty conditions of the instrument will be announced with coded messages as follows:

! Error Checksum !

Indicates a possible loss of calibration data.

Switch the instrument –OFF- and then –ON- again; if the indication persists the instrument requires a new calibration.

If the fault indication persists after the calibration procedure contact our technical staff for hardware service.

!!! Error 9 !!!

Indicates a not verified data writing on the EEPROM memory

Under

Indicates “underflow” conditions

Over

Indicates “overflow” conditions

Er r 6

Indicates that the external load exceeds the acceptable and stated limits or that the external circuit is open.

9 MAINTENANCE

The **M-CAL mA** portable calibrator has been factory tested and calibrated before shipment. The calibration should be verified and re-adjusted if the instrument is showing an error exceeding the declared specifications or when a critical active or passive component is replaced (either at component level or at board level)

The **M-CAL mA** portable calibrator uses sophisticated analog and digital technologies. Servicing requires highly trained personnel.

9.1 Safety recommendations

External circuits are normally linked to an electrical potential equal or near to the ground potential. However, in some applications, there may be present a common mode voltage to earth. Check for voltage between input terminals and ground, as this voltage can be transmitted to other devices connected to the calibrator.

9.2 Spare parts and accessories

A900032-02022	Soft case
A900032-02025	100 mA fuse
A900614-00014	Ni-MH rechargeable battery
A900032-02003	Battery charger module 120 V ac USA plug
A900032-02004	Battery charger module 230 V ac Schuko plug
A900032-02005	Battery charger module 240 V ac UK plug
A900032-02006	Battery charger module 230 V ac European plug
A900032-02007	Battery charger module 100 V ac USA/Japan plug

9.3 Storage

If the instrument is left unused for a long time, it is recommended to remove the batteries. Store the instrument in the original package at a temperature from -30°C to +60°C, with R.H. less than 90%.

If the instrument has been unused for a month check the battery voltage. Replace alkaline batteries if necessary. Recharge Ni-MH batteries, if necessary, for at least 12 hours.

10 CERTIFICATES

10.1 Warranty

Meriam warrants its products against defects in materials and workmanship. Meriam Standard Terms and Conditions are available upon request. If the unit should malfunction, it must be returned during the warranty period, transportation prepaid, to **Meriam** for evaluation. Upon examination, if the unit is found to be defective within the warranty period it will be repaired or replaced at no charge.

Meriam's WARRANTY does not apply to defects resulting from any action of the purchaser, including but not limited to mishandling, improper interfacing, operation outside of design limits, improper repair, or unauthorised modification. This WARRANTY is VOID if the unit shows evidence of having been tampered with or shows evidence of being damaged as a result of excessive corrosion, current, heat, moisture or vibration; improper specification; misapplication; misuse or other operating conditions outside of **Meriam's** control.

This warranty applies to the original purchaser only. Please include a copy of the original invoice when returning warranty items for repair.

Direct all warranty and repair requests/inquiries to the **Meriam** Customer Service Department. BEFORE RETURNING ANY PRODUCT(S) TO **MERIAM**, PURCHASER MUST OBTAIN A RETURN MATERIAL AUTHORIZATION (RMA) NUMBER FROM **MERIAM'S** CUSTOMER SERVICE DEPARTMENT IN ORDER TO AVOID PROCESSING DELAYS.

The purchaser is responsible for shipping charges, freight, insurance and proper packaging to prevent breakage in transit.

10.2 Certificate of Conformity

Each instrument is shipped with a Letter of Conformity to confirm that the characteristics of the instrument correspond to the required ones, and that the instrument calibration is traceable to National and International Standards.

APPENDIX

A1 EMC Conformity

The instrument case, made in shock-resistant injection moulded ABS + polycarbonate has an internal metal coating to fulfil the provision of the directive 89/336/CEE Electromagnetic Compatibility.
In the following page you will find the EMC declaration of conformity

A2 Declaration of Conformity

We : Meriam Process Technologies

(Supplier's name)

10920 Madison Avenue, Cleveland, OH 44102 USA

(Address)

declare under our sole responsibility that the product :

Portable indicator-calibrator type M-CAL mA

(Name and type)

p/n 3405

(Model)

to which this declaration relates is in conformity with the following normative documents :

EN 50082-2 (3/95)

IEC 1000-4-2 / IEC 1000-4-4 / IEC 1000-4-11

ENV 50140 - ENV 50141 - ENV 50204

EN 55011

(Title, number and date of issue of normative documents)

following the prevision of directive :

89/336/CEE Electromagnetic Compability (EMC)

Sesto S. Giovanni, January 08th, 1996

(Place and date of issue)

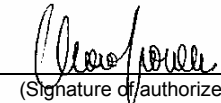
(Signature of authorized person)