

General Installation, Operation & Maintenance Instructions for MERIAM MANOMETERS

1. Uncrating & Inspection

Carefully unpack the instrument. Make a thorough check for possible shipping damage. Remove all protective cushions or plugs. If damaged, notify carrier and Meriam of damage. Be certain all items on packing list are removed from container.

2. Mounting

Mount the instrument at a convenient height for reading vertically on wall, panel, or table depending on mounting style. Be certain instrument is level. Check with level on side and front of instrument case. If instrument is furnished with a built-in level, use it to insure level mounting. Table mounting stands are shipped separate from instruments. Therefore attach the stand to the instrument.

3. Scale Adjustment (most models)

Position the scale at the center of the adjustment span.

4. Filling

U-Tube Manometers — Remove the top manometer head or fill plug. Be sure instrument is properly vented on the low pressure side. Slowly pour the selected manometer indicating fluid into the glass tube until the indicating fluid level is at approximately the zero graduation on the scale. Be sure all air bubbles are eliminated. Replace the head tightly. Adjust the scale for the correct zero position in relation to the indicating fluid meniscus.

Well Type Manometers — Remove the fill plug on the well. Be sure instrument is properly vented on the low pressure side. Slowly pour the selected manometer indicating fluid into the well until the indicating fluid level is at approximately the zero graduation on the scale. Be sure all air bubbles are eliminated. Replace the fill plug tightly. Adjust the scale for the correct zero position in relation to the indicating fluid meniscus.

Inclined Tube Manometers — Remove the fill plug. Be sure to check the instrument scale before filling to be certain the correct indicating fluid is being used. Most inclined tube manometers use Meriam 827 Red Oil or Meriam 1000 Green Concentrate. For accurate measurements, it is critical to have the correct indicating fluid in the instrument! Be sure instrument is properly vented on the low pressure side. Slowly pour the selected manometer indicating fluid into the well until the indicating fluid level is at approximately the zero graduation on the scale. Be sure all air bubbles are eliminated. Replace the fill plug tightly. Adjust the zero position by adjusting the scale or the zero adjustment knob on the well, depending on the model involved.

5. Connections to Process

It is necessary that the instrument be properly connected to the system in order to obtain a significant and accurate indication. All connections must be leak-free.

U-Tube Manometers — Either high or low pressure may be connected to either side of the instrument, provided that the difference between them is within the indicating range of the instrument.

Well & Inclined Tube Manometers — Vertical and incline tube manometers require more careful consideration. Basically, the indicating fluid will move towards the low pressure and away from the high pressure, until a hydrostatic balance has been reached. In many cases it is possible that atmospheric pressure can be considered as the high pressure. By noting the liquid level in the filled manometer, it is possible to deduce whether the visible level should be moved up or down to produce visible readings. By knowing which of the two pressures is greater (as measured from zero psia), the proper choice of meter connections can be made. It may be noted that in flow metering work using orifice plates the upstream pressure is greater than the downstream. For pitot tubes the impact pressure is greater than the static pressure.



The fluid in this product may be classified as a SARA Title III Section 313 Toxic Chemical and may be harmful to your health if spilled or released from its container. Please consult the MSDS sheet supplied with this product for detailed health and safety information and proper handling information.

The Material Safety Data Sheet is also available from Meriam Process Technologies (216-281-1100) or www.meriam.com

6. Reading

For consistent results, it is necessary that the fluid meniscus always be observed in the same way. A convex meniscus forms when mercury is used. In this instance the fluid level should be observed from the upper most point. For all other indicating fluids a concave meniscus forms. The reading in this case should be observed from the lowest point of the meniscus. To duplicate factory calibration of incline manometers, this technique needs to be followed.

It is important to remember the levels in both legs of U-tube manometers must be read and these readings added together to obtain an actual indication.

A plane tangent to the fluid meniscus and at a right angle to the tube bore intercepts the scale where it should be read.

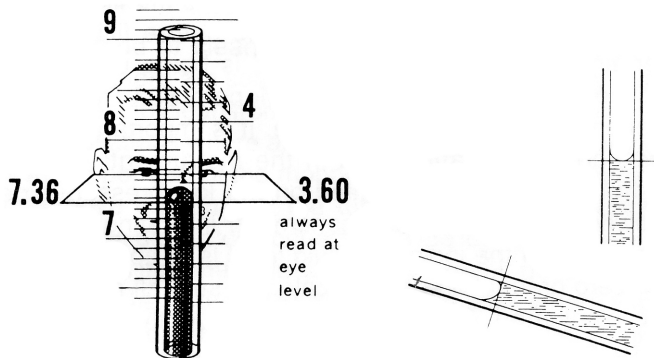

7. Theory

The fundamental relationship for pressure expressed by a liquid column is:

$$p = P_2 - P_1 = \rho gh$$

p = differential pressure

P_1 = pressure applied to one liquid surface

P_2 = pressure applied to the other liquid surface

ρ = mass density of the liquid (specific gravity)

g = acceleration of gravity

h = height of the liquid column

In the case of absolute manometers (barometers), P_1 is equal to zero absolute pressure, simplifying the equation to:

$$P = \rho gh$$

As simple as manometry is, certain aspects are often overlooked. Manometry incorporates both a value for density and gravity. These two values are not constant.

Density is a function of temperature and gravity is a function of latitude and elevation. Because of this relationship some ambient conditions must be selected as standard so that pressure bears a fixed definition.

Standard conditions for mercury used as a unit of pressure:

Gravity: 980.665 cm/sec² (32.174 ft/sec²)

at sea level and 45.544 degrees latitude

Temperature: 0° C (32° F) density = 13.5951 g/cm³

Standard conditions for water used as a unit of pressure.

Gravity: 980.665 cm/sec² (32.174 ft/sec²)

at sea level and 45.544 degrees latitude

Temperature: 4° C (39.2° F) density = 1 g/cm³

Though it is recommended that the value of a water column as a unit of pressure be at 4° C, its universal acceptance has been slow. For instance in aeronautics 15° C (59° F) is used. The American Gas Association uses 15.56° C (60° F), and in orifice flowmeter work 20° C (68° F) is commonly used.

Recognizing a manometer may be read outside, standard temperature and gravity corrections can be applied to improve the accuracy of a manometer reading at any given conditions.

Fluid Density Corrections

Manometers indicate the correct pressure at only one temperature. This is due to the fact that the indicating fluid density changes with temperature. If water is the indicating fluid, an inch scale indicates one inch of water at 4° C only. On the same scale mercury indicates one inch of mercury at 0° C only. If a reading using water or mercury is taken at 20° C (68° F) then the reading is not an accurate reading. The error introduced is about 0.4% of reading for mercury and about 0.2% of reading for water. Since most manometers are read at temperatures well above the standard temperature, corrections are needed. A simple way of correcting for the temperature error is to ratio the densities.

$$(\text{Standard}) \rho_o gh_o = (\text{Ambient}) \rho_t gh_t$$

h_o = the corrected height of the indicating fluid to standard temperature

h_t = height of the indicating fluid at the temperature when read

ρ_o = density of the indicating fluid at standard temperature

ρ_t = density of the indicating fluid at the temperature when read

Using this method is very accurate when density/temperature relationships are known. Data is readily available for water and mercury.

Density (g/cm³) as a function of temperature (°C) for mercury:

$$= 13.556786 (1 - 0.0001818 (T - 15.5556))$$

Density (g/cm³) as a function of temperature (°C) for water:

$$= 0.9998395 + 6.7982999 \times 10^{-5} (T) - 9.1060255 \times 10^{-6} (T^2) + 1.0052729 \times 10^{-7} (T^3) - 1.1267135 \times 10^{-9} (T^4) + 6.5917956 \times 10^{-12} (T^5)$$

For other fluids, manometer scales and fluid densities may be formulated to read inches of water or mercury at a set temperature. This temperature is usually ambient temperature. This decreases the error due to the temperature change, because most manometers are used at or close to ambient temperature. In some work direct readings close to design temperature are accurate enough. The manometer still only reads correctly at one temperature, and for precise work the temperature corrections can not be overlooked.

Gravity Corrections

The gravity correction arises because gravity at the location of the instrument governs the weight of the liquid column. Like the fluid density correction, the gravity correction is a ratio.

$$\text{(Standard)} \rho_o g_o h_o = \text{(Ambient)} \rho_t g_t h_t$$

$$h_o = \frac{g_t \rho_t}{g_o \rho_o} \times h_t$$

g_o = standard gravity - 980.665 cm/s²

(45.54 N latitude & sea level)

g_t = gravity at the instruments location

A 10' change in latitude at sea level will introduce approximately 0.1% error in reading. At the Equator (0°) the error is approximately 0.25%. An increase in elevation of 5000 ft will introduce an error of approximately 0.05%.

Gravity values have been determined by the U.S. Coast and Geodetic Survey at many points in the United States. Using these values, the U.S. Geodetic Survey may interpolate and obtain a gravity value sufficient for most work. To obtain a gravity report, the instrument's latitude, longitude, and elevation are needed. For precise work you must have the value of the gravity measured at the instrument's location.

Where a high degree of accuracy is not necessary and the value of local gravity has not been determined, local gravity can be calculated.

Gravity at a known latitude is:

$$g_x = 980.616 (1 - .0026373 \cos 2x + .0000059 \cos^2 2x)$$

g_x = gravity value at latitude x, sea level (cm/s²)

x = latitude (degrees)

The relationship for inland values of gravity at elevations above sea level is:

$$g_t = g_x - 0.000094H + 0.00003408 (H - H^1) \text{ (cm/sec}^2\text{)}$$

H = elevation (feet) above mean sea level

H¹ = average elevation (feet) of the general terrain within a radius of 100 miles of the point

The second term may be eliminated when H¹ is unknown, but the accuracy of the gravity determination will decrease. The degree of inaccuracy is determined by how far H¹ varies from H. In mountainous terrain this error could be large.

For every different set of conditions the significance of the corrections vary. Whether these corrections can be overlooked or not depends upon the accuracy requirements.

Other corrections do exist, but are generally outside the resolution of the instrument. For information on these considerations consult Meriam.

8. Accuracy

A manometer, when used properly, is a very accurate instrument. NIST recognizes the U-type manometer as a primary standard due to its inherent accuracy and simplicity of operation. The manometer has no moving parts subject to wear, age, or fatigue. It is simply a determination of the height of a liquid column. When the previously mentioned corrections are accounted for the uncertainty of a manometer reading is ± 1/2 the smallest graduation. This is due to your eyes ability to interpolate between the graduations.

9. Trouble Shooting

When properly selected and used, the manometer is a very accurate standard. It can, however, present what appears to be incorrect indications. These are generally the result of misapplied or improperly used pressures, or incorrectly evaluated indication.

No Reading — Pressure is not being applied to either, or both, sides of the instrument. Check for plugged or leaking pressure lines. Check internal passages of the meter for foreign particles, which may be blocking flow. Be sure atmospheric pressure connection is vented to atmosphere. Check for proper zero setting.

High Reading — Specific gravity of the indicating fluid may be too low; check scale legend and provide correct indicating fluid. With tank gauges, tank contents fluid density may be too great. If the low pressure line is above atmospheric pressure

or the high pressure line is below atmospheric pressure they should be checked for leaks or plugs. Check for proper zero setting.

Low Reading — Specific gravity of indicating fluid may be too great: check scale legend and provide correct indicating fluid. Check for leaks or plugs in high pressure line, if it is above atmospheric pressure, and or in low pressure line, if it is below atmospheric pressure. If meter has a valve by-pass line, this valve must be leak free. Check vent when used. Check for proper zero setting.

10. Maintenance

Normal maintenance necessary with Meriam manometers is the occasional cleaning of the tubes. Some manometer indicating fluids become oxidized with use. Others, over long periods of time, react with gases and fluids with which they are in contact, leaving a deposit on the surface of the fluid, and, in turn, on the tube.

Prior to cleaning the glass tube, a manometer's indicating fluid must be drained using the steam flow drain valve on well type manometers or by carefully tipping a U-tube manometer on its side. As the fluid in the manometer may be classified as a SARA Title III Section 313 Toxic Chemical and may be harmful to your health if handled improperly, please consult the Material Safety Data Sheet (MSDS) sheet supplied with this product for detailed health and safety information and proper handling information. Dispose of used indicating fluids and used cleaning materials according to local, state, and federal regulations.

The method of cleaning the various models is similar, but, there are some differences. It is generally more convenient to clean from the upper end of the manometer. On installations where accessories or piping is connected to the upper end of the manometer and it is inconvenient to remove equipment, the tube can often be cleaned through the drain plug connection in the lower channel end block. It is recommended that wherever possible the instrument be removed to a convenient table where it can be laid horizontally to afford greatest care in performing the various operations.

Meriam Cleaning Fluid

A clean manometer is essential for readability and accuracy. Meriam No. 915E cleaning fluid is recommended for use in all Meriam manometers. It is available in gallon containers only.

11. Parts

For replacement and/or spare parts request parts drawing specifying the following information.

Model number

Serial number

Range

12. Accessories

To broaden the application and simplify operation of your instrument, Meriam provides the following accessories:

Return Wells— for over-range protection

Fluid Check Valves — for over-range protection

Line Traps — to keep instruments clean by trapping dirt from the process.

Moisture & Sediment Traps — to keep instruments clean by trapping dirt from the process

Pressure Vacuum Variator.— static pressure/vacuum pressure

Valves & Piping Manifolds — to simplify different pressure measurements

Sight Feed Bubblers — for metering purge gasses

Table Mount Stands

Cleanout Bore Brushes

Seal Pots — for isolating process fluid from the instrumentation

Orifice Plates & Flanges

Meriam Instrumentation has pioneered the development and application of manometry since 1911. The highest standards of accuracy and practical, high quality design have made the words MERIAM and MANOMETERS synonymous to the engineering and research world. We welcome your inquiries pertaining to manometry, and will be pleased to help in any way we can.



a Scott Fetzer company

10920 Madison Ave.
Cleveland, OH 44102

Phone: 216-281-1100 Fax: 216-21-0228

www.meriam.com