

MERIGAUGE MODEL 3900

OPERATING INSTRUCTIONS



Meriam Instrument's MERIGAUGE Model 3900 is a microprocessor based pressure sensing gauge. The isolated sensor is all 316 stainless steel to provide compatibility with a wide variety of liquid, steam and gas processes. The MERIGAUGE is programmable, through the front keypad, to allow configuration for the user's needs. The MERIGAUGE displays the pressure value in large numerals. The user selected pressure unit is indicated on the top line of the display. A visual indication of the pressure is represented by an adjustable vertical bar graph on the left side of the display.

The standard unit is in a pipe mounted configuration with battery power. Available options include external powered units, adjustable SPDT output relays, 4 to 20 mA output, panel mounting, and intrinsically safe models.

TABLE OF CONTENTS

Keypad functions	2
ZERO Keys: Pressure zeroing the gauge	3
Other uses	3
MIN/MAX mode	4
DAMP feature	5
PROGRAM mode (PRGM): Using PRGM mode	5
Entering Numeric Values	6
"UNITS" - Engineering unit selection	6
"LOCK" - Lockout feature selection	7
"TIMER" - Unit shutoff selection	8
"SCALE" - User adjustable unit programming	8
"BARLo & BARHi" - Bar graph scale selection	9
Relay Options: "RELAY", "SET1", "SET2", "dBAND"	10
MERIGAUGE KEY FUNCTIONS diagram	11
4 to 20 mA Options: "4 - 20", "4mA", "20mA"	12
Field Recalibration	13
Full Scale Range And Resolution Chart	14
Error Codes And Messages	15-16
Installation And Maintenance:	
Mounting, Face Rotation, Battery Replacement	17-18
Wiring Diagrams	19
Outline Dimensions	20
Specifications	21

KEYPAD FUNCTIONS

ON/OFF & BACKSPACE KEY



Turns the gauge on into the **Measure Mode** and then turns the unit off from the **Measure Mode**. Also serves as a backspace key ← when editing in the **Program Mode**. The Backspace function takes the user out of a programmable register without changing the previous setting. Pressing this key repeatedly will return the user to the **Measure Mode** and then shut off the gauge. When editing a numeric value, each press of the key will backup one digit, until finally exiting the register. Note, this key will not function as an OFF key if any of the optional outputs are enabled in the output registers. Instead it will reboot the gauge if pressed.

MIN/MAX & UP ARROW KEY



In the **Measure Mode**, activates the **Min/Max** function of the gauge. When either the **Min** or **Max** is activated, the corresponding value is displayed on the upper right of the display. **Min/Max** values on the display are updated per the damp rate setting (see page 5). Pressing the **Min/Max** key once from measure mode will toggle between the MAX, MIN and Measure Mode. The Min/Max value is reset by using the zero keys (see page 3). When in **Program Mode**, pressing the Up arrow ↑ key scrolls up through the available program menu. Once a register is opened, this key allows editing by scrolling up through the options in the register. When editing numeric values, pressing the Up arrow ↑ key scrolls up from 0 - 9.

DAMP & DOWN ARROW KEY



In the **Measure Mode**, opens the **DAMP** feature for editing. When opened the current value flashes in the upper right of the display. Scrolling through the available damp rate choices is done by pressing the Up arrow ↑ or the Down arrow ↓ keys. A new damp rate is entered by pressing the **PRGM** → key, or the process can be aborted by pressing the backspace ← key. When in **Program Mode**, pressing the Down arrow ↓ key scrolls through the program menu. Once a register is opened, the key allows editing by scrolling down through the options in the register. When editing numeric values, pressing the



Down arrow ↓ key scrolls down from 9- 0.

PRGM & ENTER KEY

Puts the gauge into **Program Mode** from the **Measure Mode**. When in the **Program Mode**, pressing this key opens the program menu selected for editing. After editing the available options or numeric value, pressing the **PRGM** key enters the new selection into the gauge's non-volatile memory. This key also acts as a Forward space → key when editing user defined numeric values

ZERO KEYS: PRESSURE ZEROING THE GAUGE (OUTPUTS DISABLED)

Prior to putting into service, the MERIGAUGE should be zeroed for pressure. This will eliminate any zero drift that has occurred since manufacture. To zero the gauge, turn the unit on and then, while in the measure mode, simultaneously press the

Up arrow \uparrow and the Down arrow \downarrow keys. This should be done with no pressure applied and with the MERIGAUGE in the position it will be installed. Periodic re-zeroing may be needed to maintain the MERIGAUGE in peak operating

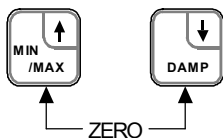

Note: All Models and ranges can be zeroed only if the new Zero is within $\pm 10\%$ of the full scale pressure. If outside this limit an “E002” error code

ZERO KEYS: OTHER USES

The zero keys are also used for the following:

- 1.) Resetting the MIN and MAX to current pressure (page 4).
- 2.) Resetting Damp rate to factory default setting (OFF, page 5)
- 3.) Resetting any Program menu option to factory default setting.
- 4.) Opening the calibration pressure registers (page 13)

ZERO KEYS: PRESSURE ZEROING THE GAUGE (OUTPUTS ENABLED)

The output options are calculated based on the displayed pressure. Since re-zeroing the gauge may change the displayed pressure, the outputs may change accordingly. For safety purposes, if the outputs are enabled, an extra step is required to warn the operator and confirm the desired action. When zeroing with an output enabled, the display will begin countdown from “5” to “0”. This initial countdown is a warning to the operator that an output is enabled and that zeroing the gauge may change the output. If you do not proceed, the gauge will count down and return to measure mode. If you choose to go ahead and rezero, press the PRGM \rightarrow key before the countdown expires. Once this is done, the display will again count down from “5” to “0”. Zeroing the gauge (simultaneously press the Up arrow \uparrow and the Down arrow \downarrow keys) during this second countdown will cause the gauge to zero.

MIN/MAX MODE

The MERIGAUGE provides a minimum and maximum hold function. The MIN value is updated whenever the current pressure drops below the stored MIN value. Similarly, the MAX value is updated whenever the current pressure increases beyond the stored MAX value. The **MIN/MAX** key toggles from Measure Mode to MAX mode to MIN mode and then back to Measure Mode.

When using the MIN or MAX modes, the corresponding value is shown on the upper part of the display and its mode indicator is illuminated. The measured pressure display continues in the large area of the display. The MIN or MAX value is always shown in the currently selected engineering units, as is the pressure display. Note, that in the MIN or MAX mode, the engineering unit text is no longer shown.

The MIN and MAX functions are always active internally in the gauge. This means that the MIN and MAX values are always updated and current, even if they are not displayed. To manually re-zero MIN and MAX values, press the zero function keys (see page 3) while in either the MIN or MAX mode. The MIN and MAX values are automatically reset when the gauge is powered on, re-zeroed, or when the engineering units are changed (page 6).

The MIN and MAX values are updated based on the currently selected damp rate. For the fastest update rate set damping to OFF. Any damping programmed in the gauge (page 5) affects the MIN/MAX update rate.

Note: See the “MERIGAUGE KEY FUNCTIONS” diagram (page 11) for further reference.

DAMPING FEATURE

The MERIGAUGE has a selectable damp rate which is used to stabilize the display for applications with a pulsating pressure source. The damp rate setting is roughly the length of time it will take for the gauge to ramp from one stable pressure to another. The ramping is exponential, changing at a slower rate as the final value is approached. Increasing the damp rate will result in a more stable pressure indication by mathematically eliminating the peaks and valleys of pulsating pressures. The selectable damp rate settings are OFF, 0.5, 1.0, 2.0, 5.0, 10, 15, 25 and 50 seconds. Pressing the DAMP key displays the current setting and repeated presses will toggle through the other selectable damp rate settings. Pressing the PRGM → key will enter the selected value. Factory default setting is OFF.

Notes: 1. See the “MERIGAUGE KEY FUNCTIONS” diagram (page 11) for further reference.

2. Damping does not effect the the 4 to 20mA or Relay Operation.

PROGRAM MODE: USING PRGM MODE

The **Program Mode** is used to configure the gauge for Measure Mode operation. The program menus that are found in the **Program Mode** are UNITS, LOCK, TIMER, SCALE, BARLo, BARHi, RELAY, SET1, SET2, dBAND, 4 - 20, 4mA, and 20mA, respectively. The MERIGAUGE can be put into the **Program Mode** at any time during Measure Mode operation by pressing the PRGM key*. The lower display will show “PRGM” and the upper right will show “UNITS”. Once in the **Program Mode**, press the Up arrow ↑ key or the Down arrow ↓ key to scroll to the desired menu. Open the desired menu by pressing PRGM again. Scroll through the menu options to the desired selection. Then enter the desired selection by pressing the PRGM key.

Pressing the PRGM key to enter a desired menu selection or numeric value returns the display to the program menu level. Press the backspace ← key to return to the Measure Mode.

* Unless Lockout is enabled (see page 7)

PROGRAM MODE: ENTERING NUMERIC VALUES

Program menus LOCK, SCALE, BARLo, BARHi, SET1, SET2, 4mA and 20mA require the user to input numeric values. The input operation is accomplished one digit at a time starting at the left (flashing). Use the Up arrow \uparrow key or the Down arrow \downarrow key to display the correct value, then press the Forward \rightarrow key to move over one place to the right. Repeat the procedure until finished with all digits. For registers other than lock, the decimal point will now be flashing. Move the decimal point to the desired location using the Up arrow \uparrow key or the Down arrow \downarrow key. To correct a previously entered position, use the Backspace \leftarrow key to backup one digit at a time. Repeated pressing of the Backspace \leftarrow key will return to the Measure Mode without entering a value. Press PRGM \rightarrow key to accept the value and complete the input.

Note: For registers that accept negative values, a prompt for the + or – sign comes before the numeric value entry. Change the sign, if necessary, by pressing the Up arrow \uparrow key or the Down arrow \downarrow key. Press the Forward \rightarrow key to accept and move to numeric editing.

Note: See the “MERIGAUGE KEY FUNCTIONS” diagram (page 11) for further reference.

“UNITS” - ENGINEERING UNITS

The standard engineering units on the MERIGAUGE are:

- | | | |
|------------------|------------------|----------|
| 1. PSI | 5. InH2O (20° C) | 9. BAR |
| 2. FTH2O (20° C) | 6. InH2O (60° F) | 10. mmHG |
| 3. FTH2O (60° F) | 7. InH2O (4° C) | 11. KPA |
| 4. FTH2O (4° C) | 8. InHG | 12. User |

To select a unit, from measure mode press the PRGM \rightarrow key. Press PRGM \rightarrow again to open the UNITS options. Use the Up arrow \uparrow or Down arrow \downarrow keys to scroll through the units to the desired selection. Press PRGM \rightarrow to enter the selection. Then press the backspace \leftarrow key to return to the measure mode.

Notes: See “Program Mode: Using PRGM Mode” (page 5) and MERIGAUGE

Key Functions” diagram (page 11) for UNIT selection instructions.

“User” units can be configured for non-standard engineering units.

See

“SCALE” on page 8 to set up a custom unit.

“LOCK” - LOCKOUT FEATURE

This feature provides security to prevent unauthorized personnel from tampering with or inadvertently changing the configuration of the gauge. The lockout is controlled by a 2-digit setting in the LOCK menu. Factory setting of L 00 indicates that the lockout is inactive. Entering a code enables the lockout feature. Note, a lockout code of L 00 to L 99 can be entered. Lockout codes 01 to 49 do not lockout the pressure zeroing function, whereas codes 50 to 99 will. All codes provide the same lockout functionality in all other aspects.

To enter a lockout code, from measure mode press the key sequence PRGM →, Up arrow ↑, PRGM →. Then enter your custom lockout code as described under “Program Mode: Entering Numeric Values” on page 6. When finished entering a code, press Backspace ← to return to measure mode.

When the lockout is enabled, any attempt to change the damp rate or enter the program mode will result in a prompt from the MERIGAUGE for a lockout code (L 00 with first “0” flashing). In addition, when the lockout code is set from 50 to 99, an attempt to re-zero the pressure will result in the lockout code prompt (lockout codes from 01 to 49 will allow pressure re-zeroing without having to enter the lockout code). If the correct lockout code is not entered an error message of “E006” is briefly displayed. In the case of damp rate or re-zeroing, the gauge will simply return to normal without accepting any change. In the case of program mode, the gauge will enter a “view only” status denoted by PRGM indicator flashing. In this mode, all menus (except “LOCK” and “UNITS”) can be viewed, but not changed.

Notes: Lockout does not affect the operation of MIN/MAX.

See “Program Mode: Entering Numeric Values” (page 6) and “MERIGAUGE Key Functions” diagram (page 11) for “LOCK” selection instructions.

“TIMER” - TIMER SHUTOFF VALUE

This feature is available on battery powered units only. This feature sets the time for automatic shutoff. The automatic shutoff can be set for “OFF”, or 1, 2, 5, 10, 15, 25, or 50 minutes. If set to “OFF” the gauge will remain on until the ON/OFF key is pressed. Factory default timer setting is 10 minutes.

To change the timer settings, from measure mode press the key sequence PRGM →, Up arrow ↑ twice, PRGM → then scroll through the desired timer setting options. Press PRGM → key to enter the the displayed selection. Then press the backspace ← key to return to the measure mode.

Note: See “Program Mode: Using PRGM Mode” (page 5) and “MERIGAUGE

Key Functions” diagram (page 11) for “TIMER” selection instructions.

“SCALE” - USER ADJUSTABLE SCALING

Allows entering of engineering units not included in the standard selection of the MERIGAUGE. The value entered will be used to linearly re-scale the full scale value (in PSI) of the MERIGAUGE. This is particularly useful for displaying non-standard pressure units or linear tank levels. The factory setting is set for the full scale range in PSI.

To enter a value, from measure mode press the key sequence PRGM →, Up arrow ↑ three times, PRGM → then enter the numeric value (see page 6). A value of .0001 to 9999 can be entered. Press PRGM → key to enter the the displayed selection. After editing the “SCALE”, the gauge automatically changes engineering units to the “User” unit and returns to measure mode.

Note: See “Program Mode: Entering Numeric Values” (page 6) and “MERIGAUGE Key Functions” diagram (page 11) for “SCALE” selection instructions.

“BARLo” & “BARHi” - BAR GRAPH SCALE

The MERIGAUGE has a 21 segment bar graph display that is fully user adjustable for visual display of any part of the pressure range. The default scaling is from 0 to 100% of the full scale range. The “BARLo” is used to set the minimum desired pressure indication in PSI and the “BARHi” is used to set the maximum desired pressure indication in PSI.

For “BARLo” the programmable range is -20% of full scale to 5% of full scale less than the BARHi setting. For “BARHi” the programmable range is 5% of full scale greater than the BARLo setting to 120% of full scale. This ensures a minimum range for meaningful bargraph operation.

For the combination vacuum gauge, both the BARLo and BARHi settings can be adjusted from -15 PSI to 120% of full scale. This provides flexibility to program a “reverse-acting” bargraph (bargraph increases with increasing vacuum). Note that, in this case, the “minimum range” is not enforced, so the user should take care to program a minimum range of 5% of full scale for meaningful bargraph operation.

To enter a value in “BARLo”, from measure mode press the key sequence PRGM →, Up arrow ↑ four times, PRGM → then enter the numeric value (see page 6). Press PRGM → key to enter the value. Then press the backspace ← key to return to the measure mode.

To enter a value in “BARHi”, from measure mode press the key sequence PRGM →, Up arrow ↑ five times, PRGM → then enter the numeric value (see page 6). Press PRGM → key to enter the value. Then press the backspace ← key to return to the measure mode.

Notes: See “Program Mode: Entering Numeric Values” (page 6) and “MERIGAUGE Key Functions” diagram (page 11) for “BARLo” and “BARHi” selection instructions.

RELAY OPTIONS

When installed, the Relay option provides two adjustable relay outputs, each with a normally opened and normally closed contact. Each of these relays can be enabled or disabled. Each relay can also be adjusted in PSI from -20% to 120% of full scale pressure (except the combination pressure/vacuum gauge, which has a lower limit setting of -15 PSI). An adjustable deadband for the SPDT relays is provided. Deadband can be set to 0%, 0.1, 0.2, 0.5, 1, 2, 5 and 10% of full scale. The relay will energize precisely at the pressure value set in the Relay feature on increasing pressure. The relay will de-energize at a value equal to the relay pressure setting, minus the deadband value, on decreasing pressure.

“SET1” and “SET2”

To enter values in “SET1” or “SET2” from measure mode press the key PRGM →, and then Up arrow ↑ until “SET1” or “SET2” is in the upper display. Then press PRGM → to enter the numeric value in PSI (see page 6). Press PRGM → key to enter the value. Then press the backspace ← key to return to the measure mode.

Note that factory defaults for the “SET1” and “SET2” registers are 0 and 100% of the instrument range, respectively.

“dBAND” (Deadband)

To select a value in “dBAND”, from measure mode press the key PRGM →, and then Up arrow ↑ until “dBAND” is in the upper display. Then press PRGM → to scroll through the desired deadband setting options. Press PRGM → key to enter the displayed selection. Then press the Backspace ← key to return to the measure mode. Note: “SET1” and “SET2” will be equally effected by the deadband value if both are enabled.

“RELAY”

Once the “SET1”, “SET2” or “dBAND” values have been entered the “RELAY” option can be enabled. To enable the Relays, from measure mode, press the key PRGM →, and then Up arrow ↑ until “RELAY” is in the upper display. Press PRGM → to enter the register, then scroll through the desired relay setting options. The choices are to have both relays turned off or to have one on and the other off or to have both relays turned on. Press PRGM → key to enter the displayed selection. Then press the Backspace ← key to return to the measure mode.

Notes: See “Program Mode: Entering Numeric Values” (page 6) and “MERIGAUGE Key Functions” diagram (page 11) for

MERIGAUGE KEY FUNCTIONS

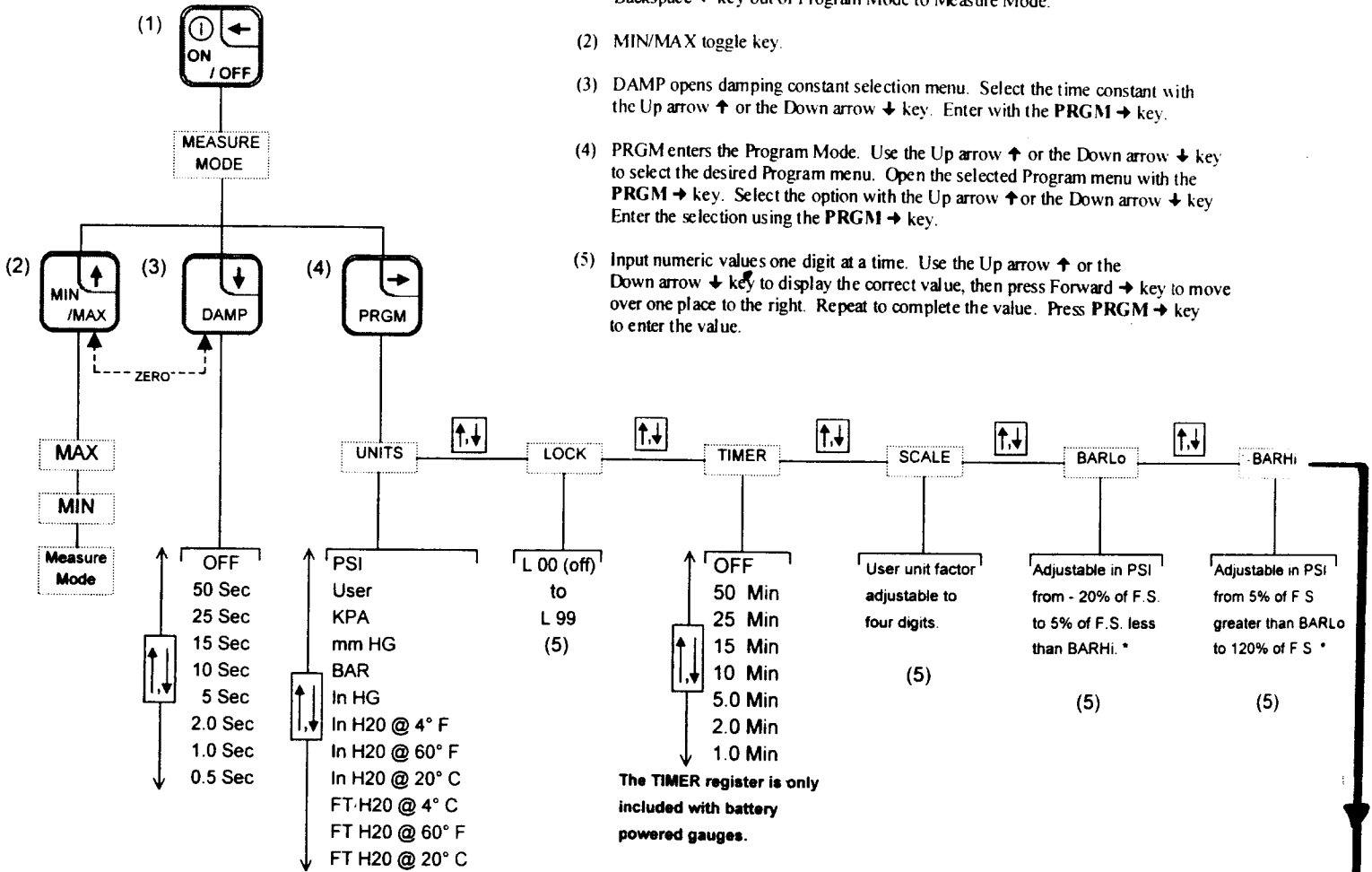

- (1) ON/OFF turns the unit on to Measure Mode and off from Measure Mode. Backspace ← key out of Program Mode to Measure Mode.
- (2) MIN/MAX toggle key.
- (3) DAMP opens damping constant selection menu. Select the time constant with the Up arrow ↑ or the Down arrow ↓ key. Enter with the PRGM → key.
- (4) PRGM enters the Program Mode. Use the Up arrow ↑ or the Down arrow ↓ key to select the desired Program menu. Open the selected Program menu with the PRGM → key. Select the option with the Up arrow ↑ or the Down arrow ↓ key. Enter the selection using the PRGM → key.
- (5) Input numeric values one digit at a time. Use the Up arrow ↑ or the Down arrow ↓ key to display the correct value, then press Forward → key to move over one place to the right. Repeat to complete the value. Press PRGM → key to enter the value.

* BARLo/BARHi can be set -15 PSI to 120% of F.S. for the combination Vacuum/Pressure Gauge
 ** -15 PSI is the lower limit for the combination Vacuum/Pressure Gauge.

Note: Refer to the appropriate section in the instruction manual for a more detailed description of each function and for programming procedures.

MERIGAUGE PROGRAMMING FLOW CHART CONTINUED...

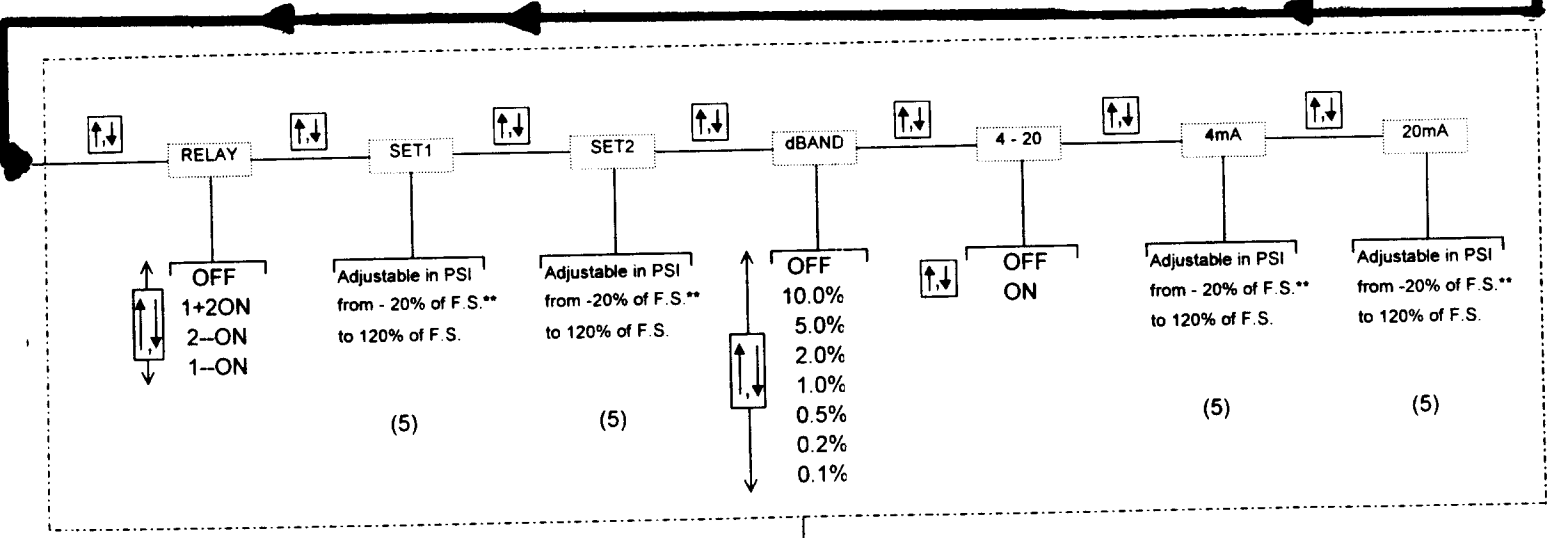

THESE FEATURES ARE OPTIONAL AND THE REGISTERS ARE ONLY INCLUDED IF THEY WERE ORDERED.

4 TO 20 mA OPTION

When installed, the 4 to 20 mA option provides an adjustable linear current output corresponding to the pressure values set at 4 mA and at 20 mA. This output option can be enabled or disabled. The 4mA and 20 mA can be set in PSI from -20% to 120% of full scale pressure (except the combination pressure/vacuum gauge, which has a lower limit setting of -15 PSI). Pressures between the 4 mA and 20 mA settings result in an output that is linearly scaled between the two values.

Note that 20mA can be set lower than 4mA for a “reverse-acting” output.

“4mA” and “20mA”

To enter a value in the “4mA” and “20 mA” register, from measure mode press the key PRGM →, and then Up arrow ↑ until “4mA” is in the upper display. Press PRGM →key to enter this register, then enter the numeric value in PSI (see page 6). Press PRGM →key to enter the value. Proceed in the same manner to set the pressure value in PSI for the “20mA” register. When finished, press the backspace ← key to return to the measure mode.

Note that factory defaults for the “4mA” and “20mA” registers are 0 and 100% of the instrument range, respectively.

“4 - 20 ”

Once the “4mA” and “20mA” values have been entered, the 4 to 20mA option can be enabled. To enable the 4 to 20 mA option from measure mode press the key PRGM →, and then Up arrow ↑ until “4 - 20” is in the upper display. Press PRGM → to enter the register, then scroll through to select either “OFF” or “ON”. Press PRGM →key to enter the displayed selection. Then press the Backspace ← key to return to the measure mode.

Notes: See “Program Mode: Entering Numeric Values” (page 6) and “MERIGAUGE Key Functions” diagram (page 11) for “4 - 20”, “4mA”, and “20mA” selection instructions.

FIELD RECALIBRATION

The MERIGAUGE can be re-calibrated at any time against any standard pressure reference that has accuracy specifications exceeding the accuracy of the MERIGAUGE. Calibration is done at three points throughout the range of the MERIGAUGE. The factory calibration is set to values approximately equal to 0%, 50% and 100% of full scale pressure in PSI. For example, a 10 PSI unit will typically have the calibration points set at 0, 5, and 10 PSI, respectively, from the factory.

The Calibration Mode is entered by pressing and holding the MIN/MAX **↑** key during power up sequence*. The PRGM, MIN, and MAX annunciators will flash to indicate that the calibration mode has been entered. The top display will indicate which point is ready to be calibrated (LOW, MID, or HIGH). The main pressure display indicates the expected pressure in PSI for that point. The PRGM **→** key is used to accept the pressure applied for the calibration point. Once the LOW point is calibrated the display will automatically advance to the MID point, and similarly to the HIGH point. The Up arrow **↑** and Down arrow **↓** keys may be used to toggle between LOW, MID and HIGH. The backspace **←** key may be used to abort the process and to turn the gauge off.

*Note: If a lockout code has been set, it must be cleared before attempting to enter

Calibration Mode, otherwise a “Lockd” message will appear.
See page 7.

Defining Pressure Points For Field Calibration

The three points of calibration are user adjustable and can be set for -5% to 25% of full scale for the low value, > 25% to 75% of full scale for the mid value, and > 75% to 105% of full scale for the high value. The factory defined calibration pressure points are roughly 0%, 50% and 100% of full scale pressure in PSI. This feature allows the user to define the exact value of the pressure reference that will be used for calibration. To redefine the pressure value at any of the three points (LOW, MID, or HIGH), simultaneously press the Up arrow **↑** and the Down arrow **↓** keys while in any of the three calibration point menus. The first digit in the upper display will flash indicating that editing can start. Enter the desired numeric value (see page 6).

Important: Changing the pressure points will shift the calibration curve. Therefore, do not edit these registers except when calibrating.

FULL SCALE RANGE AND RESOLUTION

SENSOR RANGE

	10 PSI	50 PSI	100 PSI	500 PSI	1000 PSI	1500 PSI	3000 PSI	5000 PSI	6000 PSI
PSI	10.000	50.00	100.00	500.0	1000.0	1500.0	3000	5000	6000
FTH2O	23.108	115.54	231.08	1155.4	2310.8	3466.2	6932	11554	13865
InH2O	277.30	1386.5	2773.0	13865	27730 ¹	41595 ¹	83189 ¹	138649 ¹	166379 ¹
InHG	20.360	101.80	203.60	1018.0	2036.0	3054.1	6108	10180	12216
BAR	0.6895	3.447	6.895	34.47	68.95	103.42	206.8	344.7	413.7
mmHG	517.15	2585.8	5171.5	25857 ¹	51715 ¹	77573 ¹	155146 ¹	258577 ¹	310292 ¹
KPA	68.948	344.74	689.48	3447.4	6894.8	10342.1	20684	34474	41369

Notes:

- 1.) This value will not fit on the display and will result in an error code of "E110" or "E005".
- 2.) If the published resolution will not fit with 4½ digits, the auto range feature will reduce the decimal resolution to fit.
- 3.) Add 20% for maximum pressure capacity of the gauge.

UNITS

ERROR CODES AND MESSAGES

The MERIGAUGE has an error/message feature to inform the operator of problems with the operation or programming of the gauge. These Error Codes and messages are identified and described below:

ERROR	DESCRIPTION
LO BAT	Low Battery Warning. The batteries should be replaced immediately when this annunciator is visible.
“Sensr” “FAIL” EXR=1 SGN=1	Problem with data collection. Possible cause is a loose sensor cable at the main board connector.
“T-Out”	Automatic Shutoff timer has expired; gauge is shutting down normally.
“WARN” “OP”	Overpressure warning. The measured pressure exceeds the full scale pressure by 20% of full scale or more (high or low) . Sensor is at risk of permanent damage!
“RANGE” “BAD”	Memory error. Service required.
E002	Requested ZERO value is not within 10% of full scale pressure, and thus ignored.
E005	Full Scale Range for Engineering Units selected is beyond scale of display (>19,999). This message would be seen, for example, during power up of a 1000 PSI gauge with mmHg last selected, since the corresponding full scale display of 51,715.3 mmHg will not fit on the 4½ digit display.
E006	User Entered incorrect Lockout Code. Gauge is locked. A view-only status will be entered if Program Mode was requested (see page 7). To enter calibration mode, the lockout code must first be cleared (page 13), and then the key sequence to enter calibration mode must be repeated (page 13)
E010	Requested User-Units Full Scale range is less than or equal to 0.0. Value must be greater than 0.0.
E011	Requested Bar Graph Low Value is out of range. It must be set greater than -20% of full scale sensor range, and 5% of full scale sensor range less than the BarGraph High setting. EXCEPTION:

ERROR CODES AND MESSAGES CONTINUED

E012	Requested Bar Graph High Value is out of range. It must be set 5% of full scale sensor range greater than the BarGraph Low setting, and less than 120% of full scale sensor range. EXCEPTION: Vacuum Gauge LO limit = -15 PSI, HI Limit = 120% F.S.
E020	Requested Calibration Low Value is out of range. It must be set greater than -5% of full scale sensor range and less than 25% of full scale sensor range.
E021	Requested Calibration Mid Value is out of range. It must be set greater than 25% of full scale sensor range and less than 75% of full scale sensor range.
E022	Requested Calibration High Value is out of range. It must be set greater than 75% of full scale sensor range and less than 105% of full scale sensor range.
E025	Detected pressure during calibration of the low value is out of range. Either the pressure applied is not correct, or the gauge requires service.
E026	Detected pressure during calibration of the mid value is out of range. Either the pressure applied is not correct, or the gauge requires service.
E027	Detected pressure during calibration of the high value is out of range. Either the pressure applied is not correct, or the gauge requires service.
E031 E032	Memory error. Turn Gauge off then back on if necessary (for gauges with outputs enabled, reboot the unit by pressing the ON/OFF key). If the problem persists, service required.
E110	The display value is too large to fit within the 4½ digit display (beyond ± 19999, see resolution chart on page 14)

Other Error codes indicate hardware or other internal problems; if the problem cannot be corrected by cycling the gauge on and off, please take note of the error code and operating conditions, and contact Meriam Instrument at (216) 281-1100.

INSTALLATION AND MAINTENANCE

PIPE MOUNTING

The MERIGAUGE has a 316 stainless steel $\frac{1}{4}$ " male NPT connection for direct mounting. The threads should be coated with a pipe sealant compound before installation. Torque the fitting using a $\frac{7}{8}$ inch wrench on the hex fitting above the threads. NEVER USE THE BODY OF THE GAUGE TO TIGHTEN THE THREADS.

PANEL MOUNTING

1. Determine the desired gauge mounting location.
2. Make a panel cutout and drill the mounting screw holes per the drawing.
3. Insert the gauge through the front of the panel making sure the rubber sealing gasket is positioned between the gauge flange and the mounting surface.
4. Secure the gauge to the panel with three mounting screws (not provided).
5. Connect the pressure line. Hold the $\frac{7}{8}$ inch hex nut on the stem with a wrench while tightening the pressure connection. DO NOT PUT EXCESSIVE PRESSURE ON THE GAUGE STEM AND BODY WHEN TIGHTENING. IN ADDITION, IT IS IMPORTANT TO ENSURE THAT EXCESSIVE TENSION IS NOT APPLIED TO THE GAUGE BY THE PIPING AND CONNECTION LINES.
6. Make any required electrical connections. See the wiring connection

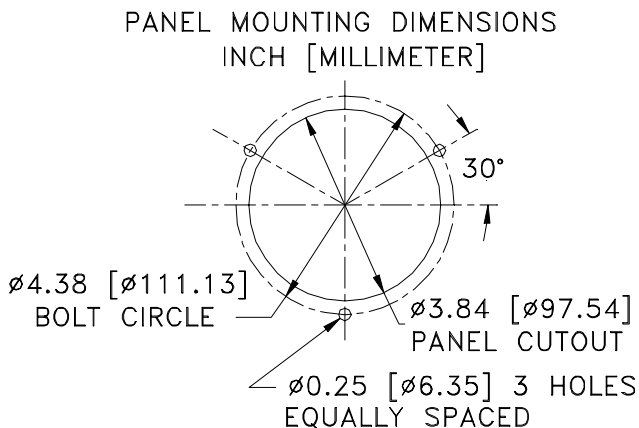

INSTALLATION AND MAINTENANCE (CONTINUED)

FACE OR INSTRUMENT BODY ROTATION

For a pipe mounted unit the MERIGAUGE can be rotated $\pm 180^\circ$ to accommodate various mounting orientations. On a panel mounted unit the case with pressure connection stem can be rotated $\pm 180^\circ$ to meet the needs of the panel installation. Simply loosen the center screw at the rear of the housing, rotate the face or instrument body and retighten the screw. To protect the internal cables, DO NOT ROTATE THE FACE OR PRESSURE CONNECTION FURTHER THAN 180 DEGREES IN EITHER DIRECTION.

BATTERY INSTALLATION / REPLACEMENT

PIPE MOUNTED UNIT:

The MERIGAUGE batteries need to be replaced when LO BAT is displayed. To replace the MERIGAUGE batteries, remove the center screw at the rear of the main housing, and carefully pull the face of the gauge from the body. USE CAUTION TO PROTECT THE CABLE FROM BEING CRIMPED, STRETCHED OR PINCHED. The best method to protect this cable is to lay the face of the gauge down on a table, with the housing laying on its back next to the face. Then, change the batteries and carefully re-assemble the gauge.

BATTERY INSTALLATION / REPLACEMENT

PANEL MOUNTED UNIT:

The MERIGAUGE batteries need to be replaced when LO BAT is displayed. To replace the MERIGAUGE batteries, the unit should be removed from the panel by disconnecting the pressure line, removing the three mounting screws, and removing the entire unit through the front of the panel. Then, remove the center screw at the rear of the main housing, and carefully pull the face of the gauge from the body. USE CAUTION TO PROTECT THE CABLE FROM BEING CRIMPED, STRETCHED OR PINCHED. The best method to protect this cable is to lay the face of the gauge down on a table,

INSTALLATION AND MAINTENANCE (CONTINUED)

WIRING CONNECTION DIAGRAMS

Note: Before making electrical connections, make sure the power supply is disconnected and secured.

All external powered units and units ordered with output options are shipped with a 6 foot wiring harness with male and female connectors included. There are two possible wiring harnesses depending on the chosen options. The wire number pin-out diagram and wire color coding diagrams are included below.

The wiring harnesses can also be removed so that the MERIGAUGE can accept other wiring directly at the auxiliary circuit board. The circuit board terminal diagram is included below. To access the circuit board, loosen the cable fitting where the harness enters the rear of the unit. Then, remove the center screw at the rear of the main housing, and carefully pull the face of the gauge from the body. Disconnect the wires from the circuit board terminals. Install the new wiring in reverse order.

Note: A hook up cable with an outside diameter of 0.114" to 0.250" is required

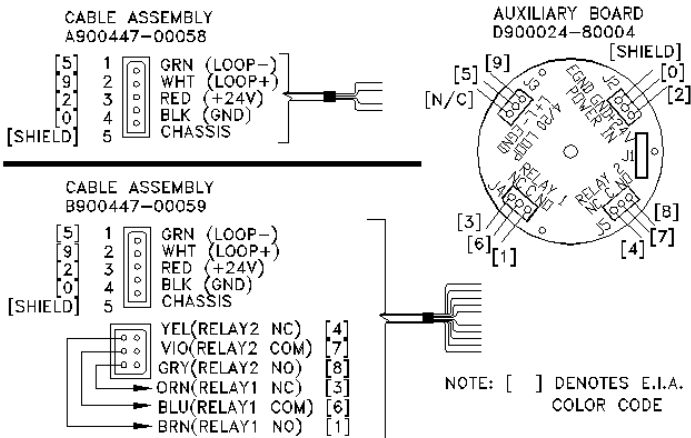

OUTLINE DIMENSIONS

PIPE MOUNT

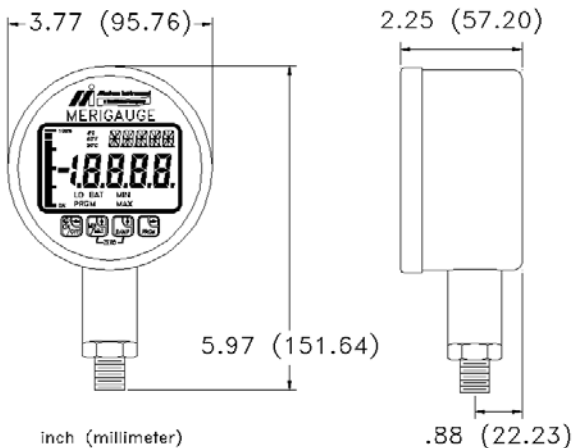

PANEL MOUNT

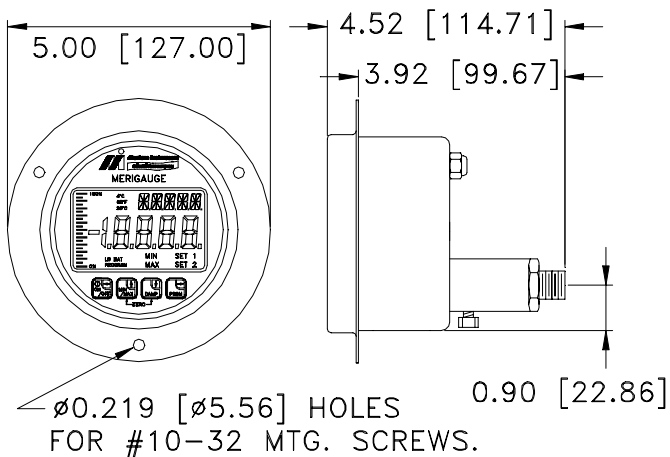

INCH [MILLIMETER]

PRODUCT SPECIFICATIONS

MODEL NUMBER	PRESSURE RANGES	OPTIONS
3900-GI0010-XX-Y-ZZ	0 - 10 PSIG	XX= 01: Standard Mount (battery power)
3900-GI0050	0 - 50 PSIG	02: Standard Mount (external power)
3900-GI0100	0 - 100 PSIG	03: Panel Mount (battery power)
3900-GI0500	0 - 500 PSIG	04: Panel Mount (external power)
3900-GI1000	0 - 1000 PSIG	Y= 1: Battery power
3900-GI1500	0 - 1500 PSIG	2: 24VDC Power (2 wire)
3900-GI3000	0 - 3000 PSIG	3: 4-20mA output (2 wire)
3900-GI5000	0 - 5000 PSIG	4: 24VDC, 4-20mA (4 wire)
3900-GI6000	0 - 6000 PSIG	5: 24VDC, 2 relay outputs
3900-VI0050	Vacuum to 0 to 50 PSIG	6: 24VDC, 2 relays, 4-20mA
		ZZ= 01: CE Approval
		02: CSA Approval

3910: Same sensor models, ranges, and options as above.

ACCURACY: 3900: $\pm 0.25\%$ of Full Scale at calibrated temperature - Standard.
3910: $\pm 0.10\%$ of Full Scale at calibrated temperature - Optional.
Temperature Drift: All models compensated to $\pm 0.01\%$ of F.S. per °C.

TEMPERATURE: Operating: 32° F to 140° F (0° C to 60° C)
Storage: -40° F to 158° F (-40° C to 70° C)

MEDIA COMPATIBILITY: Isolated sensor for liquids & gases compatible with 316SS.

PROCESS CONNECTION: ¼ inch male NPT, 316 stainless steel.

OVER PRESSURE LIMIT: Twice the full scale range.

POWER:

- Standard unit includes two replaceable standard 9 volt alkaline or optional lithium batteries. Lithium batteries are recommended for operation below 32° F (0° C). Typical alkaline battery life is ~ 1.5 years for 30 minute operation per day at room temp.
- Optional 24 VDC powered (compliance voltage: 17 VDC to 30 VDC).

OUTPUTS (Optional): • 4 to 20 mA output.

- Two programmable SPDT relays, rated 1 Amp resistive @ 30 VDC, 0.5 Amp @ 120 VAC.

DISPLAY: 4½ significant digit LCD (0.6" high) for pressure value display with a 0 to 100% vertical bar graph. Also a 5 digit alphanumeric, 0.3" high display, for unit and message display.

ENCLOSURE: NEMA 4, 304 stainless steel.

APPROVALS: CE (available), CSA/Intrinsically Safe (optional).

UNIT WEIGHT: ~ 25 Ounces depending on chosen options.

Meriam Instrument
10920 Madison Avenue
Cleveland, Ohio 44102

Telephone: (216) 281-1100

Fax: (216) 281-0228

www.meriam.com